

*Monitoring Limits on Sea-Launched Cruise  
Missiles*

September 1992

OTA-ISC-513

NTIS order #PB92-228451

# Monitoring Limits on Sea-Launched Cruise Missiles



CONGRESS OF THE UNITED STATES OFFICE OF TECHNOLOGY ASSESSMENT

# Contents

	<i>Page</i>
PREFACE .....	1
OVERVIEW AND FINDINGS .....	2
INTRODUCTION .....	3
Bilateral and Unilateral Approaches to SLCM Arms Control .....	3
Military Significance of Nuclear SLCMSs .....	5
The Debate Over SLCM Arms Control .....	5
THE MILITARY ROLES OF U.S. AND SOVIET SLCMs .....	6
Limiting U.S. SLCMs: What Might the United States Sacrifice? .....	6
Limiting Soviet SLCMs: What Might the United States Have Gained? .....	8
Asymmetries in U.S. and Soviet SLCM Forces .....	10
MONITORING METHODS AND PROBLEMS .....	11
Introduction .....	11
National Technical Means .....	11
The Limitations of Onsite Inspections .....	12
Suspect-Site Inspections .....	12
A Problem in Monitoring SLCMs: The Absence of Choke Points .....	12
On-Site Monitoring and the NCND Policy .....	13
Tags and Seals .....	14
Monitoring SLCMs at Special Verification Facilities .....	14
Radiation Detectors .....	15
Evasion Scenarios .....	17
A Worst-Case Cheating Scenario: SLCMs and the Leading-Edge Attack .....	18
ARMS CONTROL AND MONITORING OPTIONS FOR NUCLEAR	
SLCM LIMITATIONS .....	18
A Ban on Nuclear SLCMs .....	18
Production of Airframes for Nuclear SLCMs .....	19
Nuclear Warhead Production and Attachment to SLCM Airframes .....	19
Storage .....	19
Testing .....	21
Deployment .....	21
Ban Only Long-Range Nuclear SLCMs .....	21
Ban All Nuclear SLCMs on Surface Ships .....	21
Launcher Limits .....	22
Attribution Rules for Deployed Nuclear SLCMs .....	23
Limits On The Design of Future SLCMs .....	24
Politically Binding Declarations .....	24
APPENDIX .....	27

## *Figures*

<i>Figure</i>	<i>Page</i>
1. Tomahawk Mission Profiles Permit Standoff Strike .....	8
2. Tomahawk Launch Sequence From Submerged Submarine .....	9
3. Total Planned/Current Tomahawk-Capable Platforms .....	10
4. Garoma Transmission Through Simulated Conventional and Nuclear Cruise Missiles . . .	16
5. Dockside and Lighter Replenishment . . . . .	20
A-1. Tomahawk Missile System is an All-Up Round .....	27
A-2. SLCM Canisterization and Encapsulation Sequences .....	28

# Foreword

The START Treaty will not limit long-range, nuclear-armed sea-launched cruise missiles (SLCMs). Instead, the United States and the Soviet Union said they would make “politically binding” unilateral declarations of the numbers they intended to deploy.

Since the treaty was negotiated, the United States and Russia both, by reciprocal, nonbinding agreement, have removed their nuclear SLCMs from service. In a context of several thousand strategic nuclear weapons remaining on each side, the question of verifying this mutual restraint did not seem significant. Even in the context of 3,000 to 3,500 such weapons now promised as ceilings for START II, the possibility of a few tens, or even hundreds, of clandestine nuclear SLCMs may not be alarming, *especially with the end of U.S.-Soviet rivalry.*

On the other hand, if in the future the international community seeks to reduce deeply the numbers of all types of strategic nuclear weapons, SLCMs will probably have to be brought within an explicit arms control regime. This would be more the case if additional nuclear nations were to acquire long-range SLCMs.

Beginning with a hypothetical arms control regime for nuclear SLCMs, this Report examines in detail ways in which compliance with such a regime might be monitored. Surveying the life-cycle of SLCMs from development testing through deployment and storage, the assessment identifies the ‘indicators’ by which the missiles might be tracked and accounted for. It also assesses the paths of evasion that a determined cheater might take to avoid the proposed monitoring measures.

This document is the unclassified summary of a classified OTA report that was essentially completed in July 1991 and which has undergone minor updating since. The July report was the third product of an OTA assessment, requested by the Senate Foreign Relations and House Foreign Affairs Committees, centering on the technologies and techniques of monitoring the START Treaty. The first, classified, report of this assessment, *Verification Technologies: Measures for Monitoring Compliance with the START Treaty*, focuses on the START treaty and was delivered in the summer of 1990 (an unclassified summary of that report is available from OTA); the second, *Verification Technologies: Managing Research and Development for Cooperative Arms Control Monitoring Measures*, addressing the management of U.S. verification research and development, was published in May 1991; a fourth report, *Verification Technologies: Cooperative Aerial Surveillance in International Agreements*, was published in July 1991.

In preparing this report, OTA sought the assistance of many individuals and organizations (see “Acknowledgments’ ). We very much appreciate their contributions. As with all OTA reports, the content remains the sole responsibility of OTA and does not necessarily represent the view of our advisors or reviewers.



JOHN H. GIBBONS  
Director

## Start Verification Advisory Panel

Rodney Nichols  
Chief Executive Officer  
New York Academy of Sciences

James R. BlackWell  
Director, International Security  
Meridian Corporation

Ashton Carter  
Director  
Center for Science and International Affairs  
Harvard University

Sidney Drell  
Stanford Linear Accelerator Center

Richard Garwin  
IBM Fellow  
Thomas J. Watson Research Center

James Goodby  
Consultant

Andrew Goodpaster  
USA (retired)  
Chairman, The Atlantic Council

Sidney Graybeal  
Chief Scientist  
SAIC

Roger Hagengruber  
Vice President for Exploratory Systems  
Sandia National Laboratories

William R. Harris  
The Rand Corporation

Bobby Inman  
SAIC

Michael Krepon  
President  
Henry L. Stimson Center

Stephen Lukasik  
Vice President & Chief Scientist  
TRW Space and Defense Sector

Raymond McCrory  
Consultant

Ernest Mettenet  
Consultant

Stephen Meyer  
Professor  
MIT

William E. Odom, USA (Ret.)  
Director of National Security Studies  
Hudson Institute

George Rueckert  
Meridian Corporation

Albert D. Wheelon  
Consultant

Charles Zraket  
Trustee  
The MITRE Corporation

**NOTE: OTA appreciates and is grateful for the valuable assistance and thoughtful critiques provided by the advisory panel members. The panel does not, however, necessarily approve, disapprove, or endorse this background paper. OTA assumes full responsibility for the background paper and the accuracy of its contents.**

# **OTA Project Staff—Technologies for Verifying a Strategic Arms Reduction Treaty**

Lionel S. Johns, *Assistant Director, OTA  
Energy, Materials, and International Security Division*

Akin Shaw, *International Security and Commerce Program Manager*

**Thomas Karas**, *Project Director*

*Arthur Charo*

Brian McCue

Christopher Waychoff

## ***Administrative Staff***

Jacqueline Robinson-Boykin, *Office Administrator*

Louise Staley, *Administrative Secretary*

## ***Contractor***

Madeline Gross

## **Acknowledgements**

OTA gratefully acknowledges the assistance of individuals in the following organizations for their help in supplying information or in reviewing drafts of this report (the contents of the report, of course, remain the responsibility of OTA):

Arms Control and Disarmament Agency  
Defense Intelligence Agency  
Department of Energy, Office of Arms Control  
Lawrence Livermore National Laboratory  
Los Alamos National Laboratory  
M.I.T., Center for International Studies  
Office of the Chief of Naval Operations  
Pacific-Sierra Research Corporation  
Sandia National Laboratories

## PREFACE

This report is a summary and update of a study, delivered to Congress in July 1991, that examined methods to monitor Soviet<sup>1</sup> compliance with potential bilateral arms control limits on nuclear-armed sea-launched cruise missiles (SLCMs). Information in this report was last updated in November 1991<sup>2</sup>

The July 1991 report was completed before the attempted overthrow of Soviet President Gorbachev triggered a series of revolutionary events. The subsequent disintegration of the Soviet Union and the rapidly changing U.S. security relationship with the Soviet Union and its former Warsaw Pact allies challenged several longstanding tenets of U.S. arms control policy, including those regarding limitations of nuclear-armed SLCMs.

In an address to the Nation on September 27, 1991, President Bush announced a series of unilateral nuclear arms initiatives. Of particular interest for this paper was the President's directive to the Navy to withdraw all tactical nuclear weapons deployed on surface ships and submarines, including nuclear-armed SLCMs. On October 5, 1991, President Gorbachev announced a series of reciprocal unilateral arms limitations that included the removal of all nuclear SLCMs from Soviet surface ships and submarines.

OTA's study could not anticipate these events. Nevertheless, the study's analysis of the military utility of conventional and nuclear-armed SLCMs, options for SLCM arms control, and possible methods to monitor SLCMs are still relevant. For example, it provides context for evaluating President Bush's decision to withdraw all U.S. nuclear SLCMs from surface ships and submarines. In addition, the United States may wish in the future to limit SLCM production or deployment as part of a formal arms

agreement. Unilateral declarations do not have the force of international (treaty) law, nor do they provide for cooperative monitoring.

Unilateral arms reduction steps the United States might contemplate will be influenced by the degree to which the United States can be confident about the actions of potential adversaries and the consequences of undetected violations. For example, the importance of clandestine SLCM production or deployment, which the President has evidently judged relatively low, might increase should the United States and the former Soviet republics make reductions in their long-range strategic forces that greatly exceed those agreed to in the strategic arms reduction talks (START). OTA's study also analyzed the tradeoffs between monitoring confidence and monitoring complexity and intrusiveness. This issue lies at the center of all debates regarding SLCM limitations, whether accomplished by unilateral action or through arms control agreements.

Verification issues, central to previous treaty ratification debates, dominated bilateral talks about SLCM limits during START negotiations. Throughout the negotiations, the United States was steadfast in rejecting proposed limits on nuclear SLCMs because of the difficulty in finding an acceptable monitoring regime. As discussed below, monitoring SLCMs is a far more difficult task than monitoring long-range ballistic missiles or bombers.

Verification is, however, only one aspect of the debate over arms limits. In its earlier report, *Verification Technologies: Measures for Monitoring Compliance With the START Treaty*, OTA stated:

Scenarios for Soviet cheating need to be evaluated not only in terms of the technical feasibility of the potential violation, but also in terms of the probable risk, financial cost, and difficulty of the required deception; the nature of the military advantage to be

---

<sup>1</sup>At the end of May 1992, all of the former Soviet republics possessing nuclear weapons had declared their intentions to abide by the arms control commitments made by the Soviet Union. In the interest of brevity (and of consistency with the full report written before the collapse of the Soviet Union), this summary will treat the issue of SLCMs as a bilateral one between the United States and the "Soviet Union." Most of the **monitoring** issues addressed here are not affected substantively by the disintegration of the Soviet Union into sovereign states

<sup>2</sup>OTA submitted this summary for security classification review prior to publication. This accounts for most of the delay between report completion and publication.

expected from cheating; and estimates of the Soviet propensity to cheat.<sup>3</sup>

The utility of this statement is borne out by President Bush's announcement unilaterally to withdraw U.S. nuclear SLCMs with no special provisions to monitor a similar countermove from the Soviets (U.S. withdrawals were not made contingent on Soviet withdrawals, but such actions were anticipated).

## OVERVIEW AND FINDINGS

During the START negotiations, some defense analysts had argued that a mutual ban by the United States and the Soviet Union on the production and deployment of all nuclear SLCMs, or on all naval tactical<sup>4</sup> nuclear weapons, would be of net security benefit to the United States. The Reagan and Bush administrations, with the strong support of the Navy, had opposed this position. However, following the attempted overthrow of President Gorbachev in August 1991, President Bush announced a series of changes in U.S. nuclear weapons policy. These included the unilateral withdrawal of all tactical nuclear weapons, including nuclear SLCMs, from all U.S. surface ships and submarines deployed at sea.<sup>5</sup> Shortly thereafter, the Soviet Union responded with a similar pledge to unilaterally withdraw their tactical nuclear weapons at sea.

In the future, both sides might wish to enter into a formal arms agreement that would legally bind each party to SLCM limits. **Even if the United States chooses to forego a formal agreement, it will still want to monitor Russian compliance with their declarations. This summary report assesses the problems associated with monitoring agreed or declared SLCM limitations. It analyzes**

prospective nuclear SLCM arms control options, monitoring techniques, and possible evasion scenarios. With respect to monitoring regimes that would limit or ban nuclear SLCMs, but allow conventionally armed SLCMs, OTA concludes:

- prospective SLCM monitoring regimes could not detect covert nuclear SLCM stockpiles or small numbers of covert deployments; however, they could force a determined cheater to move such activities to clandestine facilities;<sup>6</sup>
- the United States could monitor day-to-day deployments of SLCMs on ships at sea through a combination of monitoring measures that might require shipboard inspections; and
- the United States would have great difficulty in detecting preparations for illegal loading of nuclear SLCMs.

**Given these monitoring difficulties, a key decision for policy makers is the appropriate level of effort and expense that should be devoted to monitoring compliance with agreed or declared SLCM limits. In addition to financial costs, the United States must also weigh the advantages and disadvantages of agreements that grant both parties equivalent rights to conduct potentially intrusive onsite inspections, for example, onboard inspections of ships capable of launching or transporting SLCMs.**

Reciprocal unilateral declarations have many similarities with more formal arms control agreements. In particular, even though reciprocal unilateral declarations carry no legal obligations, and neither side is explicitly granted monitoring privileges, each is likely to monitor the other side's compliance with their declarations by employing

---

<sup>3</sup> See *Verification Technologies: Measures for Monitoring Compliance With the START Treaty*, summary, OTA-ISC-479 (Washington DC: U.S. Government Printing Office, December 1990), p. 5.

<sup>4</sup> There is no precise definition of a "tactical" nuclear weapon. Frequently, tactical weapons are distinguished from "strategic" weapons by their shorter range. Strategic nuclear weapons include intercontinental ballistic missiles and long-range or 'heavy' bombers. These weapons have sufficient range to attack an enemy's homeland. Shorter-range tactical weapons usually operate in a particular theater and maybe used to attack an enemy's forces. Examples of tactical naval nuclear weapons are nuclear mines, nuclear depth charges, and short-range nuclear-tipped surface-to-air missiles. Nuclear sea-launched cruise missiles are usually considered tactical rather than strategic weapons, despite their capability to attack targets at ranges up to a few thousand kilometers.

<sup>5</sup> President Bush announced these changes on September 27, 1991 in an address to the Nation. The President's initiatives regarding tactical nuclear weapons include both land- and sea-based weapons. Weapons scheduled for either destruction or withdrawal to storage sites in the United States include short-range land-based nuclear weapons (nuclear artillery shells, Lance short-range missiles) and tactical sea-based nuclear weapons (nuclear SLCMs, nuclear bombs deployed at sea for carrier-based aircraft, and nuclear depth charges deployed at sea for land-based naval and carrier aircraft). The President's initiatives do not affect tactical air-based nuclear weapons, which includes nuclear bombs stored on land, that are designated for aircraft based overseas.

<sup>6</sup> Cheating might be attempted in facilities thought to be unknown to the United States, or it might occur in facilities noinspectable under treaty provisions.



*national technical means (NTM).*<sup>7</sup> However, OTA believes NTM would have limited capabilities to monitor nuclear SLCM production, storage, and deployment.

Many options are available should the United States wish to limit nuclear-armed SLCMs through a formal arms control framework that would allow monitoring more intrusive than NTM. A generic set of these options is discussed below. (The United States might also wish to postpone consideration of formal controls as a result of the actions taken unilaterally by Presidents Bush and Gorbachev in the fall of 1991.)

One potential monitoring problem for a future treaty that limited or banned nuclear SLCMs would be the development of a conventional SLCM that could be converted to a nuclear variant without extensive rework at production facilities. In general, there are two ways to design a conventional weapon that could, in principle, be covertly converted to a nuclear weapon

1. design the weapon to allow for exchange of warheads and associated systems, or
2. design the conventional warhead in such way that it could use "insertable nuclear components . . . ."

According to unclassified reports, neither of these capabilities resides in current U.S. or Soviet long-range SLCMs.<sup>8</sup> An agreement to ban development and deployment of convertible cruise missiles is probably a necessary, but far from sufficient, condition for a future agreement to control nuclear SLCMs.<sup>9</sup> A modest research program would be required to determine if a design for a verifiably nonconvertible cruise missile could be developed.

## INTRODUCTION

### *Bilateral and Unilateral Approaches to SLCM Arms Control*

Soviet proposals to include limits on sea-launched cruise missiles were among the most contentious issues during the START negotiations.<sup>10</sup> In a compromise to this longstanding dispute, the United States and the Soviet Union agreed that SLCM deployments would not be constrained by the START Treaty. However, both sides also agreed to make "politically binding" annual declarations of their planned deployments of long-range nuclear SLCMs and to accept along with (but outside) the START agreement a limit of 880 on the total number of deployed nuclear-armed SLCMs that exceed 600 kilometers (km) in range.<sup>11</sup> In addition, Presidents

<sup>7</sup> National technical means are nationally controlled intelligence-gathering systems. The explicit endorsement of NTM for monitoring arms control agreements was first made in SALT I, which, significantly, also included a provision that obligated each signatory not to interfere with the other side's NTM. Much of what constitutes NTM is classified; an unclassified example is a photo-reconnaissance satellite. See Coit D. Blacker and Gloria Duffy, eds, *International Arms Control: Issues and Agreements*, 2d. ed. (Stanford, CA: Stanford University Press, 1984).

<sup>8</sup> However, published reports have assessed Soviet short- and medium-range antiship SLCMs as being dual-capable, that is, they can be deployed in either a conventional or a nuclear variant. Presumably, warhead exchange in these systems would not require as extensive modification as in U.S. SLCMs, which are not designed to facilitate warhead exchange.

<sup>9</sup> OTA estimates that the greatest concern would be the possibility of at-sea conversion. This is especially the case if weapons were designed to use insertable nuclear components (INCs). INCs are small and their radioactive signature can be shielded; therefore, they would be difficult to find, even during an intrusive inspection. Random examinations of deployed weapons, using, for example, x-ray radiography, could reveal the existence of a cruise missile designed with a convertible warhead. (X-ray radiography measures the transmission of a beam of x-rays through an object. Just as a dental x-ray reveals the outline of a cavity, an x-ray radiograph of a cruise missile warhead could indicate the presence of structures associated with a convertible cruise missile).

<sup>10</sup> Soviet preoccupation with U.S. SLCMs had no definitive explanation. Among the possible explanations were: U.S. SLCMs threatened to negate an elaborate and costly Soviet air defense system; U.S. superiority in the enabling technologies of cruise missiles threatened to lead to a widening gap in the capabilities of future systems; and U.S. SLCMs could have been used for short-warning attacks. Soviet concerns with short-warning attacks were apparent in the Intermediate-Range Nuclear Forces negotiations when Soviet negotiators focused on the threat from the Pershing II ballistic missile, but not the subsonic ground-launched cruise missile. SLCMs also fly at subsonic speeds, but Soviet difficulties in monitoring the movements of U.S. submarines could have resulted in a concern over the possibility of a short-warning SLCM attack (see discussion of "leading-edge" attack later in this paper).

<sup>11</sup> The June 1, 1990, "Soviet-United States Joint Statement on the Treaty on Strategic Offensive Arms," specified:

SLCMs will not be constrained in the START Treaty. Each side will provide the other with a unilateral declaration of its policy conceding nuclear SLCMs and, annually for the duration of the Treaty, with unilateral declarations regarding its planned deployments of nuclear long-range SLCMs, that is, those with a range in excess of 600 kilometers. Those declarations will be politically binding. In the annual declarations the maximum number of deployed nuclear SLCMs for each of the following five Treaty years will be specified, provided that the number declared will not exceed 880.

(Note that 880 exceeded the total planned U.S. deployment) The Joint Statement also declared that both sides agree not to produce or deploy multiple warhead nuclear SLCMs. Although not part of the Joint Statement, both sides also agreed that nuclear-armed SLCMs with a range of 300-600 km would be the subject of confidential annual data exchanges: "Joint Statement on the Treaty on Strategic Offensive Arms," in *Some Key Agreements Reached At The U.S.-Soviet Summit: Washington, D.C., May 31-June 3, 1990*, U.S. Arms Control and Disarmament Agency. Also, see *Weekly Compilation of Presidential Documents*, June 1, 1990, p. 862.

Bush and Gorbachev reaffirmed a previous commitment to “seek mutually acceptable and effective methods of verification” for SLCM limitations. However, the two sides did not specify the type of SLCM limitations they might seek.

In an address to the Nation delivered on September 27, 1991, President Bush announced major changes in the current U.S. nuclear force posture and in future plans for U.S. nuclear weapon modernization. **Included in the President’s speech was a directive to withdraw unilaterally all deployed tactical nuclear systems at sea.**<sup>12</sup> These systems consisted of nuclear-armed “Tomahawk” SLCMs which can be deployed on surface ships or submarines, nuclear depth charges, and nuclear gravity bombs. Nuclear Tomahawks were ordered removed from ships and transferred to secure storage sites within the United States. The other nuclear weapons were ordered stored, dismantled, or destroyed (the age of the weapon is an important factor in determining which particular option is chosen).

The President stated that he expected the Soviets to respond to the U.S. initiative with in-kind unilateral cuts. Approximately 1 week after the President’s address, President Gorbachev announced that the Soviet Union would also withdraw its sea-based tactical nuclear weapons. Thus, through unilateral declarations, both sides achieved a result that would have been expected to be the culmination of a lengthy arms negotiations and treaty ratification process. However, mutual unilateral declarations are not equivalent to a bilateral arms control treaty because the latter imposes legal obligations on both signatories. President Bush did not propose that the Soviet Union and the United States agree to special provisions to monitor compliance with their declarations. In fact, as noted above, the administration had previously declared its opposition to SLCM arms control because of verification concerns.

President Bush’s directive calls for the withdrawal of nuclear SLCMs from U.S. ships, not their destruction or dismantlement. The Soviets have indicated a similar plan for their nuclear SLCMs. Both sides will therefore maintain a stockpile of weapons that could be deployed to any platform outfitted with SLCM launchers.<sup>13</sup> In addition, although each side is likely to reconsider its plans for future SLCM acquisition, there are no legal constraints on the production and stockpiling of existing types of nuclear SLCMs, or on the development of new types of nuclear SLCMs. Should both sides desire these limits, they could either choose to engage in formal arms control negotiations or they could again make unilateral declarations similar to those announced for deployed weapons.

**There are important differences between unilateral declarations and bilateral arms control agreements. Unilateral declarations, unless accompanied by side agreements, would not include special monitoring provisions.** For example, in both the Intermediate-Range Nuclear Forces (INF) and START agreements, each side agreed to a comprehensive set of data exchanges, weapon exhibitions, verification demonstrations and inspections (baseline, short-notice or ‘quota,’ continuous perimeter monitoring, closeout, and elimination).

President Bush’s directive also does not affect deployments of conventionally armed SLCMs. In many instances, these weapons share a similar airframe and many components with their nuclear SLCM counterparts.<sup>14</sup> Conventional SLCMs had been drawn into the debate over nuclear SLCM arms control because of the potential for clandestine production of nuclear SLCMs using conventional SLCM components and because of the difficulty in monitoring compliance with nuclear SLCM limits without also limiting conventional SLCM production and deployment.

---

<sup>12</sup> Unilateral withdrawal of U.S. nuclear SLCMs, especially from naval surface ships, had long been advocated by analysts concerned with the possibility that incidents at sea could escalate to nuclear use. To some, unilateral actions also had the advantage that they would bypass the increasingly lengthy and cumbersome arms negotiation process. Not surprisingly, an administration and Navy opposed to constraining nuclear SLCMs in a formal arms control treaty expressed no support publicly for these ideas. A summary of the advantages of proceeding unilaterally with SLCM arms control (written before the President’s surprising announcements of September 1991) appears in Douglas M. Johnston, “The Burden Lies in the Proof,” *Proceedings of the U.S. Naval Institute*, September 1991, pp. 43-48.

<sup>13</sup> Vessels in port could be loaded with SLCMs in times measured in hours; ships deployed at sea, in transit, or on training exercises might not be available for days to weeks.

<sup>14</sup> This is true for many of the Soviet antiship SLCMs and for the U.S. Tomahawk family of antiship and land-attack SLCMs (the Soviet Union does not deploy a conventional long-range, land-attack SLCM). Although conventional SLCMs are similar to nuclear SLCMs, converting one type to another is not possible without rework at the factory, unless such a feature was designed *a priori*. U.S. conventional SLCMs are not designed to allow conversion to nuclear variants.

### *Military Significance of Nuclear SLCMs*

Modern SLCMs and their air- and ground-launched counterparts bear little resemblance to their larger, less accurate, and shorter range predecessors that evolved from the German V-1 of World War II. Especially noteworthy is the development of highly accurate, long-range, land-attack SLCMs, nuclear variants of which were first deployed on U.S. and Soviet ships in the mid- and late- 1980s, respectively.<sup>15</sup> The other type of nuclear SLCM is the nuclear antiship SLCM, which does not require the sophisticated terrain-following guidance system found on land-attack weapons. An overview of cruise missile characteristics and U.S. and Soviet cruise missile programs is given in the appendix.

Land-attack nuclear SLCMs account for only a small fraction of total U.S. and Soviet long-range nuclear arsenals.<sup>16</sup> The importance of these weapons to the strategic nuclear balance appears to be greatest in the long-term, in part because of the possibility that the United States and the Soviet Union may seek mutual reductions in strategic offensive nuclear weapons that greatly surpass those agreed to in START.<sup>17</sup> SLCMs are relatively inexpensive<sup>18</sup> and in principle thousands of nuclear land-attack SLCMs (and nuclear antiship SLCMs) could be produced. However, a practical limit on the number of nuclear SLCMs that can be deployed is placed by the availability of launch platforms and launchers not already dedicated to conventional missions.

### *The Debate Over SLCM Arms Control*

Historically, the debate over nuclear SLCM arms control focused on the role of nuclear SLCMs in deterrence and their impact on “crisis stability.”<sup>19</sup> This debate began in the 1980s when it became evident that both the United States and the Soviet Union would soon deploy highly accurate long-range SLCMs capable of delivering a moderate-size nuclear weapon to inland targets after flying radar-eluding nap-of-the-Earth flight paths.

Some analysts had argued that deploying nuclear weapons on untargetable platforms would enhance deterrence. They also argued that the relatively slow speed of a cruise missile, compared to a ballistic missile, made it unsuitable for first-strike attacks and therefore a stabilizing weapon.<sup>20</sup> Others had disagreed, arguing that two-sided nuclear SLCM deployments would prove to be of net disadvantage to the United States. (These arguments are reviewed in more detail below.) The importance of this historical debate diminished when relations between the United States and the Soviet Union improved. A rational decision to risk nuclear war would occur only under improbable circumstances. With the end of the cold war and the demise of the Warsaw Pact, these circumstances appear even less probable.

President Bush’s decision to remove unilaterally all nuclear SLCMs from naval vessels may have been influenced by debates about deterrence and crisis stability, but more likely it was the direct result of a growing concern with the control and proliferation of nuclear systems and their potential for unauthorized, inadvertent, or accidental use. These concerns had always been part of the debate on

<sup>15</sup> U.S. and Soviet antiship SLCMs began development in the 1950s, but the technologies that would make land-attack SLCMs practical did not reach maturity until the late 1970s. Early versions of nuclear land-attack SLCMs were large because they were, in effect, scaled-down airplanes and notoriously inaccurate.

<sup>16</sup> As noted in the preface to this summary, nuclear SLCMs are often referred to as tactical weapons, a class of weapons that includes short-range systems such as battlefield weapons. However, because of their longer range (up to 3,000 km) and capability to execute high-accuracy strikes against land targets, SLCMs are also considered in arms reduction talks for long-range strategic systems.

<sup>17</sup> The provisions of the START treaty include a limit on the number of warheads attributed to deployed intercontinental ballistic missiles, deployed submarine-launched ballistic missiles, and heavy (long-range) bombers.

<sup>18</sup> According to the Pentagon’s Cruise Missile Project Office the average replacement cost of all U.S. land-attack and anti-ship Tomahawks—TLAM-N, TLAM-C, TLAM-D, and TASM—is about \$1.3 million (this figure includes the increase for “Block III upgrades”—the current replacement cost is \$1.2 million). (See appendix for definition and description of Tomahawk variants.)

<sup>19</sup> First-strike crisis stability refers to the incentive for one side to attack first when it fears an opponent is readying an attack. The objective of the attack would be to limit damage; it could be directed either at an enemy’s forces (“counterforce attack”) and/or at the command centers and communication networks that control the enemy’s forces. A stable condition exists when each side’s capability to deliver “unacceptable” retaliation is not impaired by being struck first.

<sup>20</sup> To achieve their long ranges, currently deployed land-attack SLCMs are powered by highly fuel-efficient miniature turbofan engines. The maximum speed of a long-range SLCM of current design is in the high subsonic range, which is similar to that which can be achieved by a commercial airliner.

nuclear SLCM arms control, but their importance increased dramatically in the aftermath of the attempted coup against Soviet President Gorbachev in August 1991.

U.S. officials feared that Soviet breakaway republics, some of which had announced their intentions to form their own armed forces, might renounce their previously stated intention to allow Moscow to retain control of nuclear weapons deployed in their territory. U.S. concerns were particularly directed at short-range 'battlefield' nuclear weapons, but naval tactical nuclear weapons present similar, if perhaps lessened, problems. The U.S. focus on the command and control of Soviet tactical nuclear systems is partly explained by noting that the Soviets had already announced they were reviewing procedures that control authority over "central" strategic weapons—intercontinental ballistic missiles and long-range bombers. These forces are usually believed to be easiest to control because they are relatively few in number and because they are not dispersed widely.

The President did not explain why tactical naval nuclear weapons were included with battlefield weapons in his call for mutual unilateral arms limits. Some analysts have speculated that the longstanding interest among Soviet leaders in limiting U.S. nuclear SLCMs and other tactical naval nuclear weapon deployments may have influenced President Bush's decision to include them in a package that Secretary of Defense Dick Cheney said would make

... the world's arsenal of nuclear weapons significantly smaller and the world safer, and ... give the Soviets the incentive they need to shift their country away from the business of cranking out nuclear weapons and toward the work of building democracy.<sup>21</sup>

Changes occurring in the former Soviet Union may alter perceptions of the Soviet incentive to cheat on arms control agreements and the likelihood that "militarily significant" violations could occur without detection by the United States. For example, events following the Soviet coup demonstrated that violation of an agreement or a unilateral declaration could face an increased risk of exposure from within

the military and from an increasingly independent Soviet press. In addition, the development of new parliamentary bodies, the emergence of independent republics, the demise of the Communist Party, and the greatly diminished influence of the KGB in Soviet affairs are factors that may reduce the incentive for cheating. It also appears that massive budget shortfalls and the necessity to secure Western economic assistance (which may be tied to reduced military expenditures or specific arms reductions) have forced Soviet leaders to make substantial cuts in at least some military programs.

## THE MILITARY ROLES OF U.S. AND SOVIET SLCMs

The rest of this summary is divided into sections that discuss the military utility of nuclear and conventional SLCMs as well as arms control monitoring options and methods. As noted above, conventional SLCMs were drawn into the debate over limitations for nuclear SLCMs because of their potential use in a clandestine program to produce nuclear SLCMs.

The net security benefit to the United States of limiting nuclear SLCMs through arms control would depend on the advantages of limiting Soviet SLCMs, the disadvantages of comparable limits on U.S. SLCMs, and the consequences of potential violations of these limits.

### *Limiting U.S. SLCMs:*

#### *What Might the United States Sacrifice?*

*In the past*, U.S. officials opposed to limits on Navy nuclear SLCMs argued that U.S. nuclear SLCMs:<sup>22</sup>

- augmented the nuclear reserve and thereby enhanced the nuclear deterrent;
- complicated the Soviet defense problem because nuclear SLCMs could be deployed on many untargetable platforms;
- were stabilizing weapons because they could not be targeted in a Soviet first-strike and were not suitable for a U.S. first-strike;

---

<sup>21</sup> Secretary of Defense Dick Cheney, quoted in "Excerpts From Briefing at Pentagon: 'It Will Make the World a Safe Place'" *The New York Times*, Sept. 29, 1991, p. A-10.

<sup>22</sup> See Linton Brooks, "Nuclear SLCMs Add to Deterrence and Security," *International Security*, vol. 13, No. 3, winter 1988/89, pp. 169-174. This article was written when Navy Capt. Brooks was the Director of Arms Control on the National Security Staff. He was appointed acting head of the U.S. START delegation in June 1991 following the resignation of Ambassador Richard Burt.

Figure 1—Tomahawk Mission Profiles Permit Standoff Strike

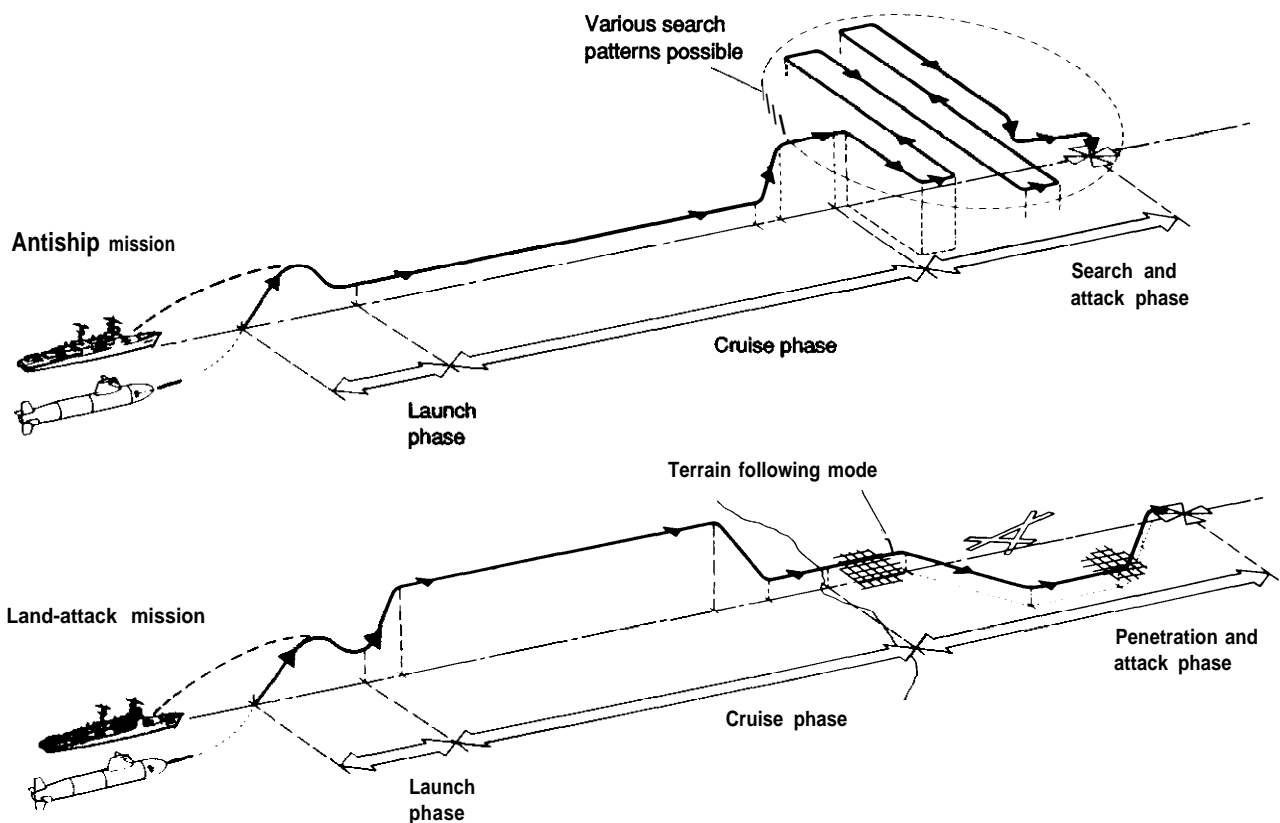

SOURCE: Department of Defense.

along with 527 antiship Tomahawks and 975 conventional land-attack Tomahawks.<sup>29</sup>

*Limiting Soviet SLCMs:*

*What Might the United States Have Gained?*

The Soviets might have used their SLCMs to:

- attack U.S. Naval vessels, especially aircraft-carrier battle groups;
- serve as reserve weapons for the main Soviet strategic nuclear force;<sup>30</sup>
- act as the leading edge of a frost-strike attack intended to weaken U.S. retaliation in a strategic nuclear war;
- serve as major counterforce weapons against U.S. missile silos and bomber bases;

- attack strategic targets in Europe or the Far East; and
- project power against minor powers and in the third world.

Antiship missions may require several hundred antiship SLCMs (not necessarily nuclear) to be distributed across many platforms. Historically, the Soviet Union devoted a considerable effort to this mission, as demonstrated by their development and deployment of dedicated SLCM-carrying submarines. To date, it appears that a similar effort to develop land-attack capabilities has not been made.

Even after START reductions, hundreds or thousands of nuclear land-attack weapons would be necessary to make a significant contribution to

<sup>29</sup> Public Affairs and Congressional Relations Office, Cruise Missiles Project and Unmanned Aerial Vehicles Joint Project Office, Jan. 15, 1991. Note these figures were issued prior to the onset of Desert Storm.

<sup>30</sup> Dennis M. Gormley, who has studied SLCM verification for the Department of Energy's Office of Arms Control, suggests this as the most plausible mission for Soviet long-range nuclear SLCMs. Dennis M. Gormley, "How To Think About Verifying Limits on Nuclear-Armed SLCMs," *Arms Control*, vol. 10, No. 3, December 1989, pp. 289-299.

Figure 2—Tomahawk Launch Sequence From Submerged Submarine

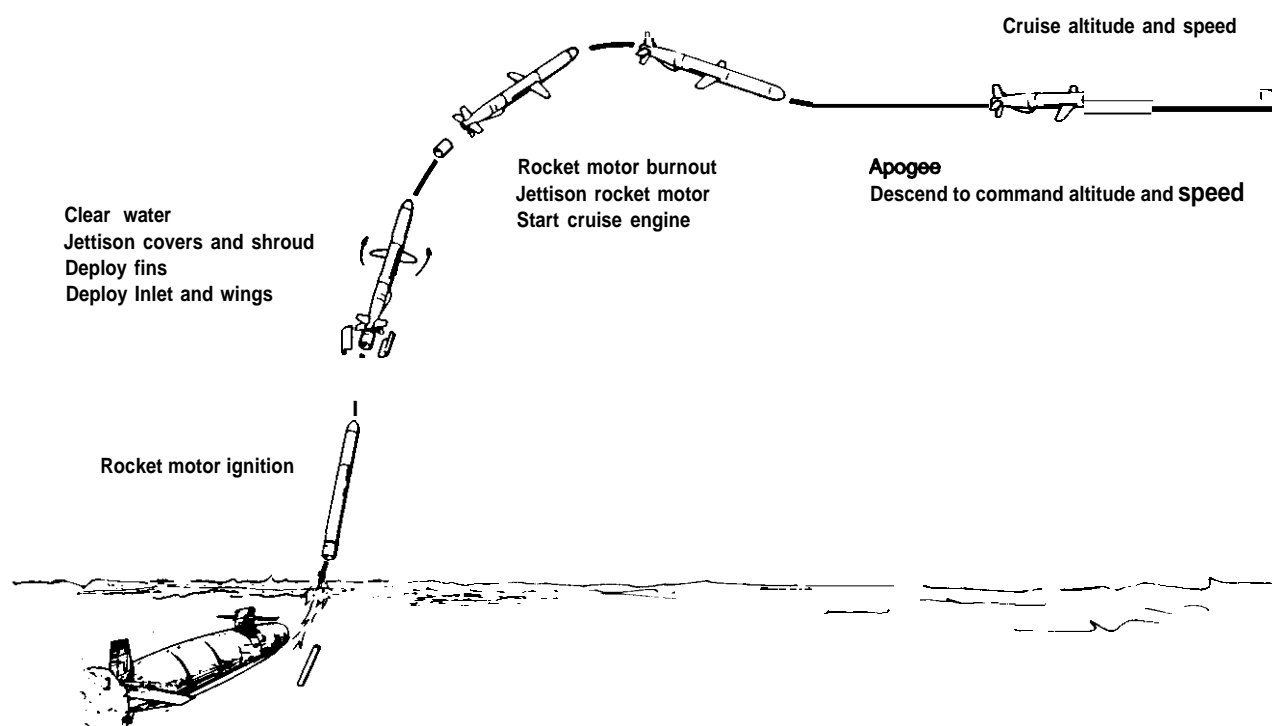

SOURCE: Department of Defense.









strategic reserve, the second mission. The third mission-leading-edge attack-would be a small surprise attack that might target key U.S. command, control, and communication facilities, potentially delaying or blunting U.S. response to a larger follow-on nuclear attack. Many military analysts question the plausibility of this scenario. The leading-edge attack is a relatively high-risk attack that would require near-perfect surprise and near-perfect timing and coordination for success (see below). Currently, SLCMs carry a single warhead. Hundreds or thousands of land-attack SLCMs would therefore be necessary to mount a major counterforce attack, the fourth possible mission (assuming that these weapons had the requisite combination of accuracy and yield to be capable of destroying hardened targets).

For missions such as power projection, the Soviet Union might have wanted to develop a long-range, conventional land-attack capability. The current lack of such a capability could reflect historical emphasis on deploying SLCMs for antiship roles (mostly to counter U.S. naval forces), or it could

reflect problems in developing a guidance system with sufficient accuracy to make target destruction by conventional (versus nuclear) attack possible. The United States was able to develop a "terminal" guidance system for SLCMs by drawing on advances in computing and microelectronics, areas in which the Soviet technology base is relatively weak. On the other hand, it is possible that the effective use of conventional land-attack Tomahawk SLCMs by the United States in the 1991 Gulf War could spur interest in the development of a similar weapon by the others.

In Summary, many analysts saw the greatest potential cost to the United States of limiting nuclear SLCMs as the possibility that arms control arrangements might also limit conventional SLCMs. (Although some officials were adamant in their argument that nuclear SLCMs were too important to the United States to be traded away.) The greatest threat from Soviet SLCMs in the short-term appears to be from antiship weapons. However, in the long-term, the greatest threat might come from land-attack SLCMs.

Figure 3-Total Planned/Current Tomahawk-Capable Platforms<sup>a</sup>

USN Surface ships			USN Submarines		
	Planned	Current		Planned	Current
BB	Battleship	2	SSN-637	Surgeon class	24
		2			20
CGN	Nuclear guided missile cruiser	5	SSN-688	Los Angeles class	62
		5			35
CG	Guided missile cruiser	22	SSN-21	Seawolf class	29
		12			0
DD	Destroyer	31	Total submarine (approximate) 90*		
		16	55		
DDG	Guided missile destroyer	39*	*Total number of tomahawk capable submarines to be approximately 90 based on commissionings/decommissionings.		
		0	Total number of tomahawk capable submarines to be approximately 90 based on commissionings/decommissionings.		
Total surface ship		99	55		

● Projected

<sup>a</sup>Total number of Tomahawk capable submarines to be approximately 90 based on commissionings/decommissionings.

<sup>a</sup>Force structure plans depicted here were current in January 1991. Substantial revisions have occurred since that time. For example, Seawolf production may cease after the second or third submarines.

SOURCE: Cruise Missile Project Office.

*Asymmetries in U.S. and Soviet SLCM Forces*

The differing missions of the U.S. and Soviet navies<sup>31</sup> and the historical advantage of the United States in cruise missile technologies are reflected in the characteristics of currently deployed SLCM forces. These asymmetries complicate prospective SLCM arms control measures. For example, the United States deploys only one SLCM with a range below 600 km, the conventionally armed antiship Harpoon (range 110 km). In contrast, nearly all of

the Soviet Union's more numerous SLCMs have ranges below 600 km. These weapons are thought to be designated for antiship missions and they are deployed on a variety of surface ships and dedicated cruise missile submarines (SSGs). Most have also been designed to allow deployment with either a conventional or a nuclear warhead.

Asymmetries also exist in long-range SLCM programs. Although both nations deployed long-range nuclear-armed land-attack SLCMs, the Soviet

<sup>31</sup> According to former Chief of Naval Operations Admiral Carlisle A.H. Trost, U.S. SLCMs were initially developed to "meet the threat posed to our naval forces by the unprecedented Soviet buildup over the past 20 years and their development of anticarrier weapons and tactics." Adm. Trost also stated that because the United States is a maritime nation with global overseas commitments and strong multilateral and bilateral cooperative agreements with maritime allies, the U.S. Navy requires "capable, ready, forward deployed naval forces-forces that can operate in international waters, uninhibited by unrealistic restrictions on movement." Adm. Carlisle A.H. Trost, USN, Senate Armed Services Committee, Subcommittee on Projection Forces and Regional Defense, *Approaches to Naval Arm Control*, S. Hrg. 101-1002, May 8, 11, 1990.

program lagged that of the United States. In addition to a possible numerical advantage, the United States can disperse its nuclear SLCMs on both surface ships and nuclear attack submarines. In contrast, the Soviet Union deployed its nuclear land-attack SLCMs only on a few submarines.<sup>32</sup>

During the START negotiations, President Bush committed the United States to seek mutually acceptable and effective methods of verification for SLCM limitations. However, neither he nor other members of the Administration specified the types of SLCM limitations that would be acceptable to the United States. In fact, since some officials opposed SLCM limits of any kind, finding an acceptable means of verification for SLCMs was only a necessary prerequisite for consideration of a SLCM treaty.

This summary presents several hypothetical arms control options for SLCMs — including their potential costs, risks, and benefits — contained in the OTA report delivered to Congress in July 1991. However, it does not provide a judgment on the desirability of any particular option. As its baseline analysis, this report surveys the possible ways to monitor compliance with a treaty that would ban the production, deployment, or storage of nuclear SLCMs of any range. All conventional SLCMs, stored or deployed, that might plausibly be converted into nuclear SLCMs might also be accounted for in this treaty option. Possible ways of monitoring compliance with this hypothetical treaty account for the bulk of this Summary. This report also briefly examines the monitoring implications of less comprehensive SLCM arms control arrangements.

## MONITORING METHODS AND PROBLEMS

### *Introduction*

Opportunities to monitor SLCMs exist at several stages in their production, test, deployment, and maintenance “lifecycle.” Employment of increasingly intrusive inspections and monitoring techniques at each stage might yield improvements in the

United States’ overall confidence that a restricted activity was not occurring. **However, monitoring limitations on nuclear-armed SLCMs is likely to present a substantially more difficult task than monitoring limitations on ballistic missiles or strategic bombers. There is likely to be continuing uncertainty in the U.S. assessment of the number of Soviet nuclear SLCMs produced and, to a lesser extent, the number of SLCMs deployed.**<sup>33</sup> Negotiated measures to enhance verification could reduce, but not eliminate, these uncertainties. For those in favor of limiting SLCMs through formal arms control agreements, the challenge will be to find a combination of measures (i.e., a monitoring regime) that will be able to deter (detect) “significant” cheating without imposing too much of a burden on the United States. Below is described the range of measures from which such a regime might draw.

### *National Technical Means*

Historically, the United States has placed great reliance on NTM to monitor Soviet compliance with treaty limits on ballistic missiles and bombers. However, OTA believes NTM is limited in its capability to monitor many of the steps in the cruise missile production-to-deployment lifecycle.

The Soviet SLCM lifecycle would be difficult to monitor with NTM for several reasons. SLCMs are small and production or assembly facilities may be indistinguishable from other light industry. Transportation of SLCM components, or even a fully assembled weapon, does not require road or rail vehicles of distinctive size or shape. SLCM tests could occur at clandestine sites or at times when NTM assets are not on station. In addition, tests could be conducted at less than full range, or at full range in racetrack patterns, that might be hard to detect with overhead systems. Static engine tests could occur indoors and thus also escape detection by overhead systems. Finally, the Soviet Union is under no legal obligation to allow the United States to receive telemetry data from cruise-missile tests.<sup>34</sup>

<sup>32</sup> The only currently deployed long-range Soviet SLCM is the nuclear-armed land-attack SS-N-21.

<sup>33</sup> Revolutionary changes underway in the former Soviet Union might alter this evaluation. For example, with the lifting of state controls on the Press and other information sources, it is likely that the United States will have more knowledge of all Soviet military programs, including SLCMs.

<sup>34</sup> During the START negotiations, the United States did not favor a ban on data denial for cruise missile tests. This is in contrast to the ban on denial of telemetry from ballistic missile tests to which both sides agreed.



### *The Limitations of Onsite Inspections*

The INF and START agreements use onsite inspections to supplement NTM. However, the utility of onsite inspection in monitoring SLCMs would be limited by the greater ease of establishing clandestine production or storage facilities. Monitoring SLCM deployments during shipboard inspections is another possibility, but, as discussed below, U.S. officials believe it would be highly intrusive. The value of shipboard inspections in an arms control monitoring regime is also disputed by those analysts who focus on the potential for clandestinely produced SLCMs to be hidden and subsequently dispersed in a crisis. Shipboard inspections could not prevent this 'breakout' scenario, but they could assist the United States in monitoring day-to-day SLCM deployments.

### *Suspect-Site Inspections*

"Anywhere-anytime" suspect-site inspections might make it more difficult for the Soviets to cheat on a SLCM arms accord, but they would impose financial and other costs on the United States because of the reciprocal inspection rights that would be given to the Soviet Union. Furthermore, to restrict Soviet access to sensitive U.S. facilities, suspect-site inspections would likely be accompanied by a limited right of refusal. This would reduce the effectiveness of suspect-site inspections.

Many analysts are convinced that the Soviet Union would never allow U.S. inspectors to confirm a violation, even if suspect-site inspections were not limited. In practice, at least several hours would pass before inspectors would reach a suspect-site. During this time, evidence of certain types of violations (e.g., illegal storage) might be hidden. U.S. NTM assets are not available continuously; therefore, the United States might not be aware of unusual activity at a suspect-site prior to an inspection (the United States could, however, try to time its suspect-site inspection to coincide with the availability of NTM assets). Inspectors traveling to a suspect-site might be also delayed by their hosts in a way that would be

difficult to establish as a deliberate attempt at deception. For example, inspectors might be informed of an unexpected "problem" in the mechanical condition of their air or ground transports. **The chance of actually uncovering illegal production or storage of treaty-limited SLCMs in a suspect-site inspection would therefore be small.**<sup>35</sup> Nevertheless, some analysts believe that suspect-site inspections can act as a deterrent to cheating at undeclared sites.

### *A Problem in Monitoring SLCMs: The Absence of Choke Points*

The INF treaty included a ban on intermediate-range ballistic missiles, most notably the Soviet SS-20. Monitoring compliance with this ban was eased by the existence of bottlenecks or "choke points" in the production-to-deployment path of the missile. Choke points are facilities that cannot be easily bypassed. For ballistic missile production, an example is the plant where first-stage rocket motors are mated to upper missile stages (the "final missile assembly facility").<sup>36</sup> There is no equivalent monitoring choke point for a SLCM, therefore, **OTA believes that the path of a SLCM from production to deployment does not require any test, or include any facility, that could not be circumvented by a determined cheater.** In addition, a determined adversary could conceal the signatures now associated with the safety and security of nuclear warheads movement and storage.

The few facilities where nuclear warheads are attached to SLCM airframes might appear to be a choke point in the nuclear SLCM logistics path. However, a determined cheater could arrange for warhead attachment to occur in any number of clandestine facilities. These could be located at military bases, or even at civilian industrial sites. The principal barrier to cheating, other than the risk of exposure, would be the potential loss in nuclear weapon control and (possibly) an increased safety hazard.

<sup>35</sup> The problems experienced by trained United Nations inspectors charged with monitoring destruction of Iraqi weapons of mass destruction following the Gulf War illustrates the limitations of suspect-site inspections. It is notable that these problems occurred in a nation that had been defeated in a war (and therefore had limited means to thwart inspections) and that was being threatened with reprisals for noncompliance.

<sup>36</sup> Note that some missiles, notably the U.S. Peacekeeper, are assembled in their silos and not in separate assembly facilities. The Soviet final missile assembly plant in Votkinsk is the site for final assembly of the SS-20 intermediate-range ballistic missile (banned by INF) and the SS-25 intercontinental-range ballistic missile (allowed by INF). The United States chose to exercise its INF treaty right for onsite monitoring at Votkinsk. The Soviets setup their monitoring station around the U.S. site in Magna, Utah, that formerly produced the first-stage, solid-rocket motor of the treaty-limited Pershing II.

Another problem in monitoring SLCMs at warhead attachment facilities is the intrusiveness of the inspection process. Historically, U.S. and Soviet arms control treaties have granted each side reciprocal monitoring rights. Thus, a treaty provision that allowed the United States access to a warhead attachment facility in the Soviet Union would also allow Soviet access to a U.S. facility. Currently, the United States attaches nuclear warheads to Tomahawk cruise missile airframes within naval weapon-handling areas. OTA estimates that the potential for compromise of sensitive intelligence and the disruption of normal operations would be greater at these sites, than, for example, at the INF-allowed Soviet perimeter-portal monitoring site at Magna, Utah. In general, inspection procedures become much more intrusive as the size of a treaty-limited item decreases.

The INF treaty included a ban on ground-launched cruise missiles (GLCMs) with ranges between 500 and 5,500 km (thus, in effect, banning all U.S. and Soviet GLCMs deployed or in development).<sup>37</sup> **Although there is no choke point for GLCM production, monitoring was greatly eased by the INF Treaty ban on both conventional and nuclear GLCMs and on the elimination of all GLCM launchers.**<sup>38</sup> In contrast, an arms control treaty for nuclear SLCMs would most likely allow conventional SLCMs and their launchers to remain unconstrained. As noted above, the United States has been adamant in its opposition to treaty-imposed limits on conventionally armed SLCMs because these weapons now have essential roles in land-attack and antiship missions.

A SLCM treaty that allowed conventional SLCMs would preserve much of the "infrastructure" necessary to produce nuclear SLCMs. Nuclear SLCMs differ from conventional SLCMs mostly in the front end of the missile, where the warhead and guidance system are housed. Another potential source of SLCM components, including guidance system, propulsion system, and possibly nuclear warheads, would be nuclear air-launched cruise missiles (ALCMs).

The START treaty does not contain provisions that limit or account for the number of nondeployed ALCMs.<sup>39</sup> It also does not control the production of nuclear warheads. Many of the Soviet antiship SLCMs, including modern weapons such as the SS-N-12 and SS-N-19, are "dual-capable," that is, they can be deployed with either a conventional or a nuclear warhead. A covert conversion from a conventional variant to a nuclear variant would be especially simple in these weapons. However, the Soviet Union developed only a nuclear variant for its sole long-range SLCM, the land-attack SS-N-21. This might make covert production of SS-N-21s relatively more difficult.

### *On-Site Monitoring and the NCND Policy*

On-board inspection of ships is a key element in many prospective SLCM arms control monitoring schemes. The U.S. Navy had opposed shipboard inspections, partly because the practice would have compromise their longstanding policy of neither confirming nor denying (NCND) the presence of nuclear weapons. The purposes of the NCND policy include having the freedom to navigate waters declared nuclear-weapon-free zones, unrestricted port calls abroad, and a reduced threat from terror-

<sup>37</sup> Nuclear and conventional ground-launched cruise missiles and their launchers were banned by the INF Treaty. The INF treaty entered into force on June 1, 1988. The treaty calls for the elimination over a 3-year period of all ground-launched nuclear force missiles, including cruise missiles, in the 500-5,500 km range. The treaty also bans new production of these systems. U.S. missiles captured under INF limits are the Pealng II and Pershing IA ballistic missiles and the Tomahawk ground-launched cruise missile (GLCM). Soviet systems affected by the Treaty include the SS-20 and SS-4 intermediate-range ballistic missiles, shorter-range SS-12 and SS-23 ballistic missiles, and the SSC-X-4 GLCM, which was never deployed.

<sup>38</sup> U.S. judgments about monitoring requirements may also have been influenced by the fact that Soviet GLCMs posed no threat to the U.S. mainland.

<sup>39</sup> Nondeployed air-launched cruise missiles (ALCMs) are not constrained by the START treaty, but there is a prohibition on the storage of ALCMS at bomber bases declared to be non-ALCM heavy bomber bases (for example, the B-1B bomber base at Grand Forks AFB, North Dakota). Deployed systems are treaty accountable and their numbers will count using an attribution rule against START's 6,000 warhead ceiling.

Only nuclear-armed ALCMs with a range in excess of 600 km, long-range nuclear ALCM (LRNA), will be accountable under START. For purposes of counting against the 6,000 warhead limit, accountable warheads will be attributed to heavy bombers equipped for LRNA as follows: each current and future U.S. heavy bomber equipped for LRNA will count as 10 warheads but may actually be equipped for up to 2 LRNA, (except as noted below). Each current and future Soviet heavy bomber equipped for LRNA will count as 8 warheads but may actually be equipped for up to 16 LRNA, (except as noted below).

The United States may apply the above counting rule to 150 heavy bombers equipped for LRNA; the Soviet Union may apply the above counting rule to 180 heavy bombers equipped for LRNA. For heavy bombers equipped for LRNA in excess of these levels, the number of attributable warheads will be the number of LRNA for which the bombers are actually equipped. Each heavy bomber equipped only for nuclear weapons other than LRNA (i.e., only for gravity bombs and short-range attack missiles) will count as 1 warhead under the 6,000 limit.

ists. As a result of President Bush's order to withdraw all tactical nuclear weapons from naval vessels, only U.S. strategic missile submarines (SSBNs) will carry nuclear weapons, and the NCND policy is effectively nullified.<sup>40</sup> However, the Navy also opposed shipboard inspections because of a concern that ship vulnerabilities, damage control methods, quieting techniques (especially important on submarines), and the distribution of different types of offensive and defensive weapons would be disclosed.

Proponents of SLCM arms control differed sharply with these views. Some analysts believed that the importance of the NCND policy was overstated. Others, believing that adherence to the NCND policy led to a 'crisis with New Zealand and friction with Australia, China, and Denmark,'<sup>41</sup> suggested that the United States would benefit from a complete abandonment of the NCND policy.<sup>42</sup> President Bush's order to remove tactical nuclear weapons from naval vessels should end this controversy.

SLCM arms control proponents also believed that fears of intelligence losses during shipboard inspections were exaggerated. They noted, for example, that the United States agreed to intrusive monitoring provisions for START verification.<sup>43</sup> In addition, both sides agreed to measures to minimize the potential for disclosure of sensitive information during these inspections.<sup>44</sup>

### *Tags and Seals*

A "tag" is a nonreplicable identification marker that could be used to identify a specific treaty-limited item (TLI) as legal or illegal under treaty provisions. A seal maybe used to attach a tag to a TLI in such a way that any attempt to remove it would be detectable. Seals could also be used independently of tags to produce tamper-proof

enclosures. Tags and seals are often proposed for application to SLCM monitoring, but they are a relatively immature technology and their incorporation in arms control monitoring of SLCMs faces numerous practical problems. START negotiators considered, but later rejected, proposals to use tag and seal technologies to assist in monitoring of mobile ballistic missiles.

To date, only the reflective particle tag ("glitter paint") is fully developed and subject to adversary analysis ("Red Teamed"). Seals appropriate for cruise missile canisters are still in early stages of development. Incorporating tags or seals in a practical monitoring regime requires agreement on operational issues such as: where and how devices are to be affixed, where and how they are to be inspected, and how to minimize Soviet opportunities for collecting intelligence during inspection.

### *Monitoring SLCMs at Special Verification Facilities*

This report's primary case study is of a hypothetical arms treaty banning the production, deployment, and storage of nuclear SLCMs of all ranges. A notional regime to monitor compliance with this agreement would begin by verifying through onsite inspection that existing stockpiles of SLCMs are legal (non-nuclear). Both sides might wish to avoid the potential disruption and intelligence losses that could occur if inspections are allowed at contractor sites or naval weapon handling facilities. This argues for the creation of special verification facilities (SVFs) located onshore.

A treaty barring all nuclear SLCMs might simplify inspection procedures needed at an SVF because neither side would fear that intrusive inspection could reveal nuclear warhead design or

<sup>40</sup> Some might argue that the Navy would want to retain the NCND policy as part of a contingency to reintroduce tactical weapons some time in the future. However, the logic of this position is contorted, as the Navy could not simultaneously refuse to confirm or deny the presence of nuclear weapons and be in compliance with a Presidential directive (issued through the Secretary of Defense) to remove these weapons.

<sup>41</sup> New Zealand breed ports of call by U.S. ships that might be carrying nuclear weapons and withdrew from a U.S.-backed @~ alliance in the region. President Bush's directive to remove tactical nuclear weapons from mval ships has led New Zealand to take preliminary steps to rescind these policies. See Smith, op. cit., footnote 24, p. A-40.

<sup>42</sup> Michael C. Pugh, "Verification of Naval Nuclear Weapons: A Red Herring?" *Naval Forces*, vol. 11, No. 6, 1990, pp. 8-14.

<sup>43</sup> These include allowing Soviet inspectors at U.S. missile and submarine bases to count the number of warheads on -- and submarine -based ballistic missiles. Soviet inspectors will also be allowed at certain bomber bases. For examplonsite inspection of bombers, weapon storage areas, and maintenance facilities will be permitted at non-ALCM heavy bomber bases to confirm the absence of bombers equipped for cruise missiles and the absence of ALCMs.

<sup>44</sup> For example, reentry vehicles and weapons in storage and maintenance areas will be shrouded during inspection.

specific weapon vulnerabilities.<sup>45</sup> The establishment of special inspection facilities would require a complementary program of inspections of SLCM platforms to insure that all deployed SLCMs had passed through the inspection facility. If SLCM tag/seals were developed, they might be applied in the SVF and read during shipboard inspections (tags could be read at loading and unloading facilities or when they cycled through maintenance facilities, but this would allow a determined cheater to elude detection). SLCMs stored and fired from canisters could have a tamper-revealing seal attached to the canister instead of on the missile itself. Candidate seals include fiber-optic nets, which are discussed in the previously cited OTA report on verification technologies for START. It may be possible to design these nets so as not to interfere or prevent SLCM launch while providing a means to verify that the warhead section of the cruise missile has not been tampered with.

### *Radiation Detectors*

The characteristic signatures of nuclear material can be used to distinguish between conventional and nuclear SLCMs (in effect, these signatures are “intrinsic” tags).<sup>46</sup> All nuclear weapons contain several kilograms of either uranium-235, a rare (0.7 percent) isotope of natural uranium, or plutonium-239, an element, not found in nature, produced in quantity in nuclear reactors by reaction with uranium-238. These elements can sustain the nuclear chain reactions essential to create either a fission nuclear weapon or a thermonuclear weapon (which uses a fission weapon to trigger nuclear fusion).

Isotopes of plutonium and uranium undergo spontaneous fission to lighter and more stable elements. Energy released during fission decay is emitted in the form of particles and radiation, mostly neutrons and gamma-rays. The presence of U-235, Pu-239, or other nuclear material (e.g., U-238) likely to be present in a nuclear SLCM could be detected by monitoring these emissions. Alternatively, the presence of nuclear material could be inferred by observing the attenuation of an x-ray or gamma-ray beam as it passed through dense nuclear material, or by detecting emissions from fissions induced by passing a beam of neutrons or gamma-rays through the warhead. (See figure 4.)

Radiation detection techniques that require an external source of radiation are referred to as “active,” while techniques that monitor only intrinsic emissions are “passive.” Passive techniques are generally less complex and require less cooperation from the inspected party than do active techniques. Small, portable passive detectors have been proposed for shipboard inspections. There are many possible ways to detect nuclear material with active techniques.<sup>47</sup> However, in general, these techniques appear more appropriate for onshore inspection.

An inspector searching for nuclear material with passive radiation devices would attempt to distinguish intrinsic radiation from background radiation.<sup>48</sup> To detect a SLCM in a launcher would also require detecting nuclear material through the SLCM canister (if canisterized) and launch tube. SLCMs stored below the deck of a ship would be shielded by the ship’s layers of steel (steel is approximately half

<sup>45</sup> If necessary, sensitive information related to the operation of conventional SLCMs could also be protected. For example, inspections could use only passive radiation detectors, which detect only emitted radiation. Alternatively, negotiators could agree to limits on the capabilities of active sensors. “CARGO-SCAN” is an x-ray device that is employed by the United States at the portal to the Soviet final rocket assembly plant at Votkinsk. It produces an x-ray shadowgram that allows inspectors to detect the small differences in length and diameter that distinguish INF treaty-limited SS-20 from an allowed SS-25 (both missiles leave the plant enclosed in an opaque canister). However, the operation of CARGO-SCAN and the portion of a missile canister that is allowed to be inspected is carefully controlled (the central portion is not imaged) to prevent potentially sensitive information from being revealed.

<sup>46</sup> There is already a precedent for the use of radiation detectors in arms control treaty monitoring. The INF Treaty allows the United States to take benchmark measurements of neutron emissions on Soviet SS-20 and SS-25 missiles, which are then used as the basis for comparing measurements taken during subsequent inspections. The neutron measurements allow the United States to verify that only single-warhead missiles (characteristic of SS-25 ICBMs), and not treaty-banned three-warhead SS-20s, are present at former SS-20 bases.

<sup>47</sup> For example, gamma-ray radiography would monitor the attenuation of a collimated beam of gamma-rays as it passed through various parts of a cruise missile warhead. Fissile materials are strong absorbers of both low- and high-energy gamma-rays. Intense and energetic beams of gamma-rays could be generated by accelerator techniques; less intense and less energetic sources could be derived from naturally occurring radioisotopes. Gamma-ray radiography appears to offer a definitive check on the presence of fissile material in current cruise missile designs.

<sup>48</sup> On a ship, strong sources of background radiation could come from nuclear weapons, nuclear propulsion units, ammunition containing “depleted” uranium (i.e., uranium left over from the enriching process that concentrates U-235—use of such high-density material increases the penetrability of the ammunition), and naturally occurring trace radioisotopes. The intrinsic radiation from a nuclear warhead will be attenuated by its passage through intervening materials that include chemical high-explosive, fuel, warhead casing, and missile skin.

Figure 4-Gamma Transmission Through Simulated Conventional and Nuclear Cruise Missiles

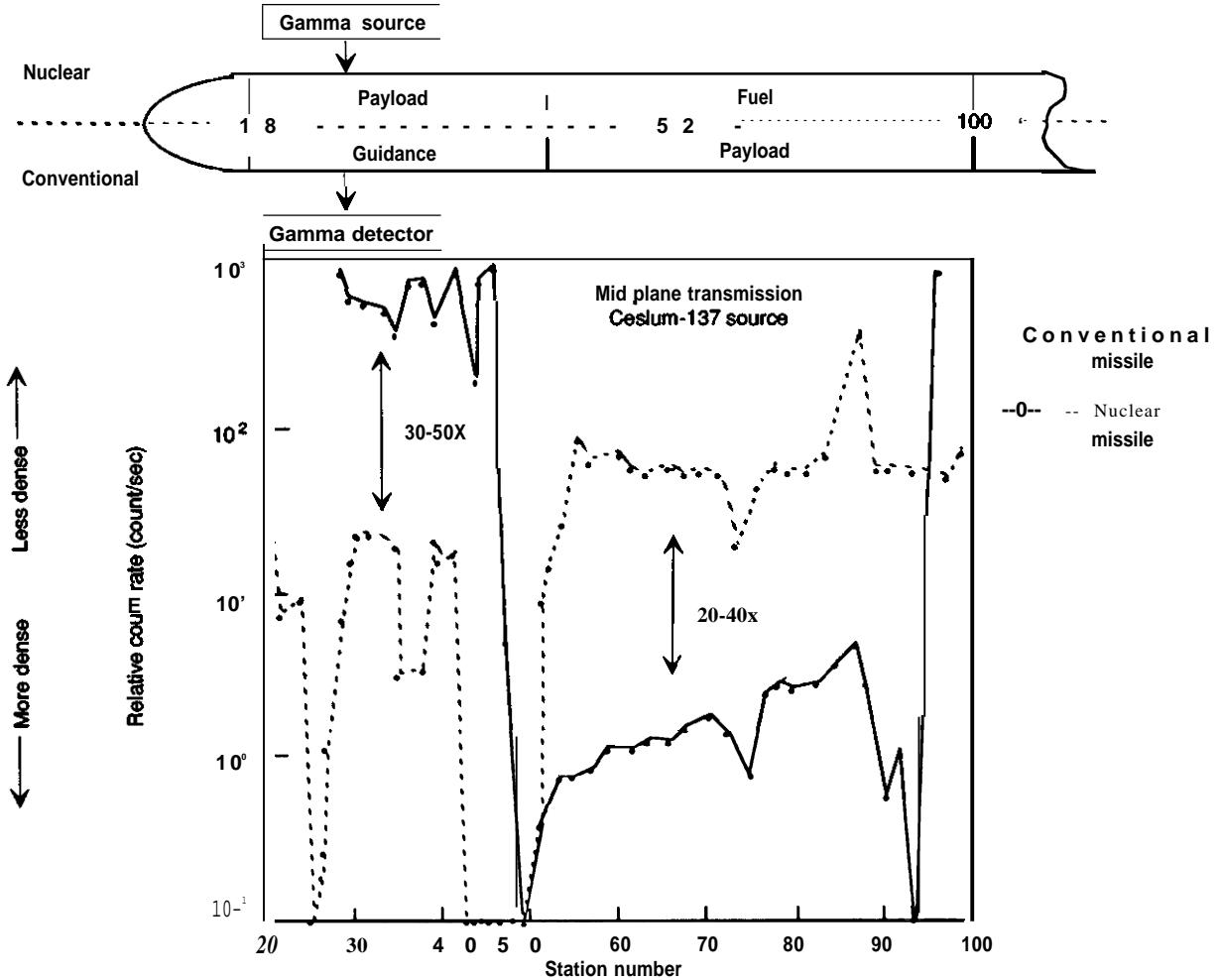

The axial variation in transmission of 662 keV radiation from cesium source for conventional and nuclear cruise missiles using a simulated (concrete) conventional warhead, a mook W84 warhead, and water to simulate fuel.

SOURCE: Lawrence Livermore Laboratory.

as effective in shielding gamma-rays as lead, a very strong absorber of gammas).

An experiment sponsored by the Natural Resource Defense Council employed high-resolution gamma-ray spectrometers<sup>49</sup> to detect a nuclear SLCM aboard the Soviet cruiser *Slava*. Experimenters had little difficulty in detecting intense gamma radiation from the decay of uranium-235 and plutonium-239 and concluded that these emissions could have

been detected through the launch tube at a distance of 4 to 5 meters. In addition to detection, an analysis of the data also allowed researchers to glean some information about warhead composition and basic design.<sup>50</sup>

The results of the NRDC experiment were expected—researchers had little doubt that a sensitive gamma-ray spectrometer would be able to detect the presence of an unshielded nuclear warhead. The

<sup>49</sup> Uranium and plutonium isotopes emit high-energy gamma-rays at specific energies as they radioactively decay. A high-resolution gamma-ray spectrometer is a device that allows the measurement of gamma-ray energy and intensity with great precision.

<sup>50</sup> Steve Fetter, et al., "Measurements of Gamma Rays from a Soviet Cruise Missile," in Frank von Hippel and Roald Z. Sagdeev, (eds.), *Reversing the Arms Race: How to Achieve and Verify Deep Reductions in the Nuclear Arsenals* (New York, NY: Gordon and Breach, 1990). Note that disclosure of nuclear design information would not be a concern in a treaty regime that banned all nuclear SLCMS; such disclosure would merely add to the risk of cheating.

practicality of incorporating gamma detectors, or other radiation detectors, in an arms control monitoring regime that includes shipboard inspections rests on a number of issues outside the scope of the *Slava* experiment.

For example, could a determined cheater design a warhead with a reduced signature?<sup>51</sup> Would a determined cheater be able to hide nuclear warheads or insertable nuclear components below deck and convert conventional SLCMs to nuclear variants after an inspection?<sup>52</sup> Would a concerted search by inspectors be acceptable to both sides? Would it even be possible for both sides to agree on the use of intrusive radiation detection technologies? Would less intrusive radiation detectors be useful?<sup>53</sup> An important practical problem in negotiating the use of such devices is that both sides must be convinced the instruments employed could not gather sensitive data covertly (assuming other “legal” nuclear weapons were onboard).<sup>54</sup>

### *Evasion Scenarios*

“Evasion scenarios” are potential ways to circumvent or cheat on the provisions of a nuclear SLCM arms control agreement. The United States might discover evidence of cheating through its national technical means; through human intelligence; or through fortuitous discovery; for example, evidence provided by a defector.<sup>55</sup>

An adversary analysis can produce a seemingly endless assortment of ideas for cheating (or legal

circumvention), measures that might deter these evasion paths, and countermeasures to these measures. Judgments about the plausibility of a particular cheating scenario are subjective, as analysts will disagree on the ‘penalty’ of trying to incorporate an illegal force with a legal force, the probability and consequences of detecting a violation, and the effects of the changing U.S.-Soviet security relationship.

**Although a SLCM arms control verification regime could not prevent violations, it might act as a deterrent by making cheating more risky or expensive. An important objective of an arms control verification regime would be to make preparations for militarily significant violations difficult to conceal. Baseline inspections, exchanges of information, and monitoring of declared facilities might aid in this objective, in part because they would force cheating to occur at clandestine facilities. However, they could not prevent a determined cheater from producing and stockpiling at least small numbers of illegal weapons.**

A concern among some analysts is the possibility of a SLCM “breakout,” the rapid deployment of many SLCMs from onshore stockpiles to SLCM-capable vessels. No arms control treaty can prevent breakout. However, a treaty’s monitoring and data exchange provisions might increase the likelihood of detecting preparations for breakout. In addition, some treaties might reduce breakout “potential.” For example, a limit on the number of SLCM-

51 One evasion scenario would be for a cheater to design a single-stage warhead composed only of highly enriched uranium (U-235); this warhead’s gamma-ray emissions would be less energetic and therefore more difficult to detect. Evasion might be more difficult if inspectors combined neutron detection with gammadetection. Neutrons are more difficult to shield than gamma-rays and the neutron background intensity usually varies less than the gamma background. Furthermore, neutron shields are not very effective for gamma-rays, even at low energies. Sources: Briefings to OTA, Los Alamos National Laboratory, Aug. 17-18, 1989 and Briefings to OTA, Lawrence Livermore Laboratory, Nov. 30, 1989. A detailed technical analysis for this and other evasion schemes appears in Steve Fetter et al., “Detecting Nuclear Weapons,” op. cit., footnote 50.

52 Spoofing of the detector by placing shielding within the cruise missile is not thought to be plausible because it would make the missile too heavy to fly. Spoofing might be possible by placing shielding in the cruise missile’s shipping container, launch canister (for SLCMs that are canisterized), or launch tube. To deter this evasion scenario, a monitoring regime could specify procedures to allow random inspection of a sample of SLCMs that had been removed from their containers, canisters, or launch tubes. If developed, tamper-revealing seals might also find application in defeating evasion schemes that use shielding (see discussion in text).

53 For example, less intrusive passive radiation detectors include gamma-ray detectors that are restricted in the energies they can detect, or gamma detectors altered in such a way as to restrict their spatial resolution (i.e., deliberately “blurring” the image).

54 For example, it is possible to use “coded apertures” (complex versions of pinhole cameras) to make a gamma-ray camera that would have a limited spatial resolution. An advantage of this device is that the highest spatial resolution of the camera is limited in an unambiguous way for a particular set of apertures. Other ideas for limiting the resolution of imaging systems envision the use of special software image processing programs. However, even with safeguards, there is a concern that a cheater could embed a program in computer memory and use it to reconstruct higher resolution data. Briefing to OTA, Los Alamos National Laboratory, 1989. The resolution of gamma-ray imagers is discussed in *Verification Technologies* (U.S. Department of Energy, Office of Arms Control, Jan./Feb. 1990), pp. 10-11.

55 An example of the importance of fortuitous discovery is seen in revelations made in the summer of 1991 of an Iraqi program to produce highly enriched uranium. According to press reports, one source of evidence for such a program came from hostages released from captivity in Iraq in the winter of 1990. An analysis of the clothes of some of the hostages found evidence (from embedded particles) that suggested they had been held near a uranium enrichment facility. Later, an Iraqi defector confirmed the existence of a clandestine program to produce enriched uranium.

capable platforms, or the number of SLCM launchers, might limit the utility of very large covert stockpiles of nuclear SLCMs in a breakout scenario. The benefits and drawbacks of this approach are discussed later.

### *A Worst-Case Cheating Scenario: SLCMs and the Leading-Edge Attack*<sup>56</sup>

Some analysts argue that even a few tens of nuclear land-attack SLCMs could pose an important military threat because of the possibility that they could be used in a surprise attack on key elements of the U.S. strategic command, control, and communications network. The United States has not developed or deployed an air defense system specifically designed to detect the current generation of Soviet land-attack cruise missiles. Next-generation weapons would be even harder to detect if they incorporated stealth technology. Moreover, the launch platforms for these weapons would include very quiet submarines.

Other analysts are less disturbed by this threat. They note that a “leading-edge” SLCM attack is plausible only if it could be executed with near total surprise. Operationally, this may be difficult because it could require a coordinated attack by several platforms firing multiple SLCMs. To be successful, preparations for the attack, which could include the transit of SLCM platforms to launch points near the U.S. coast, would have to go undetected. Moreover, land-attack cruise missiles, which currently travel at subsonic speeds, would have to arrive on target before the United States could react. The flight time for a SLCM fired 500 miles from its target is approximately 1 hour. In contrast, a surprise attack by Soviet submarine-launched ballistic missiles could be executed at much longer ranges and with only 15 minutes or less of tactical warning.

**OTA judges that no plausible arms control monitoring regime could reliably detect small numbers of illegal deployments.** To the extent that small numbers of Soviet nuclear land-attack SLCMs are of concern, they must be dealt with independ-

ently of arms control, for example, by developing and deploying SLCM warning systems. Proposals for such systems have been made in the past, but there is little enthusiasm to develop them now because of the relaxation in tensions accompanying the end of the Cold War. In fact, parts of the U.S. air defense and aerial surveillance modernization program have recently been curtailed or canceled.<sup>57</sup> President Bush’s decision to remove all bombers and some missiles from alert status, the Air Force’s decision to remove 24-hour airborne alerts for its airborne command post “Looking Glass,” and the Navy’s decision to eliminate airborne alerts of its submarine communications relay aircraft “TA-CAMO,” are all evidence that a surprise nuclear attack—whether by nuclear SLCMs, bombers, or missiles—is of diminished concern.

## ARMS CONTROL AND MONITORING OPTIONS FOR NUCLEAR SLCM LIMITATIONS

OTA analyzed monitoring options and evasion possibilities for several representative proposals for nuclear SLCM arms control regimes. These are summarized below.

### *A Ban on Nuclear SLCMs*

This option would ban the production, storage, and deployment of any type of nuclear SLCM. OTA addressed this option in greatest detail because:

- the asymmetry in numerical deployments and capabilities of U.S. and Soviet land-attack and antiship SLCM forces suggested that this option could be of mutual interest,
- this option most clearly illustrated the tradeoffs between monitoring confidence and monitoring complexity and intrusiveness, and
- this option provided a natural point of departure for an analysis of arms options that would explicitly allow some types of nuclear SLCM deployments.

<sup>56</sup> The leading-edge attack is discussed in more detail in Arthur Charo, *Continental Air Defense: A Neglected Dimension of Strategic Defense*, CSIA Occasional Paper No. 7 (Lanham, MD: University Press of America), 1990.

<sup>57</sup> Until recently, Air Force P@ for their O<sub>ver</sub> the-horizon backscatter radar network included a North-Central site, which when combined with coastal OTH-B facilities would have given wide-area ocean surveillance at all altitudes from the coast line to some 1,500 miles offshore. These plans have now been canceled and the only operational facility, located in Maine, has been reduced to part-time operation. OTH-B was designed primarily to track bomber-sized targets; however, supporters believed that detection of cruise missiles would also be possible. See *Continental Air Defense*, *ibid.*, pp. 74-80.

A range of onsite monitoring options could be applied at some or all of the lifecycle stages of SLCM component production; component assembly and missile test, deployment, and maintenance. These options could be tailored to satisfy the tradeoff between monitoring uncertainty and the financial costs, potential for disruption, or intelligence losses associated with implementing U.S. inspections and preparing for Soviet reciprocal inspections. For example, if the United States was mostly concerned about day-to-day compliance with the ban on nuclear SLCM deployments, and it did not want to tolerate Soviet inspectors on U.S. ships, it could implement an inspection regime that would only examine SLCMs onshore. One option would be to examine a random sample of SLCMs during loading or unloading operations. More intrusive regimes could add monitoring at warhead attachment facilities, storage sites, or production facilities.

It is OTA's assessment that there are many ways a cheater could violate covertly a treaty that forbade **any** nuclear SLCM production, storage, or deployment-if the cheater is willing to tolerate the risks and potential penalties of cheating. Illegal nuclear SLCMs could come from weapons hidden before treaty entry-into-force, SLCMs produced at covert facilities, or illegal conversion of conventional SLCMs (which are assumed to be legal) to nuclear variants. ALCMs are another potential source of SLCM components-including engines, guidance systems, and possibly nuclear warheads. As noted above, START places no restrictions on the production of ALCMs.

The legal production and deployment of conventional SLCMs and nuclear ALCMs in this notional treaty option guarantees that much of the necessary "infrastructure" for test and manufacture of nuclear SLCMs would remain available after treaty entry-into-force. Continuous in-country monitoring at declared production and assembly facilities and onsite inspection of SLCM platforms would force a cheater to establish and maintain a covert infrastructure. However, even the most intrusive monitoring, including short-notice anywhere, anytime' inspections, could not guarantee that some illegal SLCMs

were not being hidden. In a crisis, these SLCMs could be deployed rapidly to SLCM-capable surface ships or submarines.

The monitoring challenge for a total ban on all nuclear SLCMs, including nondeployed weapons, may be illustrated by enumerating some of the potential evasion routes a **determined** cheater might consider for the production, storage, test, and deployment portions of the nuclear SLCM lifecycle. (Note: the following list represents OTA judgments and does not purport to represent judgments of the U.S. Government.) A more detailed analysis, not possible in this unclassified summary, **suggests** that some of these scenarios would be more worrisome than others.

#### *Production of Airframes for Nuclear SLCMs*

- Modify existing conventional SLCM airframes.
- New production at facilities that are legal for conventional SLCMs.<sup>58</sup>
- Production from air-launched or ground-launched cruise missile parts.<sup>59</sup>
- Production at clandestine facilities.

#### *Nuclear Warhead Production and Attachment to SLCM Airframes*

- *Covert* assembly of nuclear SLCM warheads at facilities involved in legal nuclear warhead production.
- Divert/modify nuclear warheads designated for nuclear-armed ALCMs.
- Attach warheads at clandestine industrial site.

#### *Storage*

- Hide nuclear SLCMs within the confines of conventional SLCM production plants.
- Hide nuclear SLCMs at undeclared military facilities.
- Hide nuclear SLCMs at industrial facilities (assuming cheater is prepared to assume the risks that might accompany less secure storage of nuclear weapons).

<sup>58</sup> There is no 'externally observable indicator' that could be used to distinguish between the production of an airframe designed for a nuclear SLCM and the production of an airframe designed for a conventional SLCM.

<sup>59</sup> Although ALCM production is not restricted by the START agreement, both conventional and nuclear ground-launched cruise missiles (GLCMs) and their launchers were eliminated by the INF treaty.



Figure 5-Dockside and Lighter Replenishment

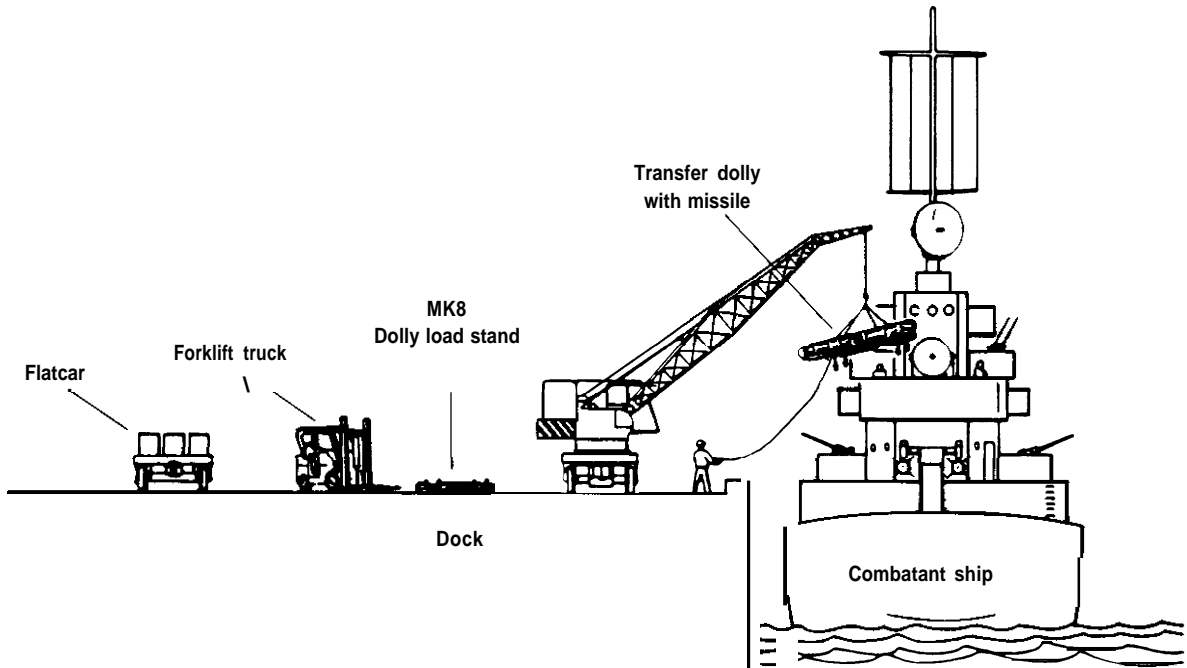

Dockside replenishment

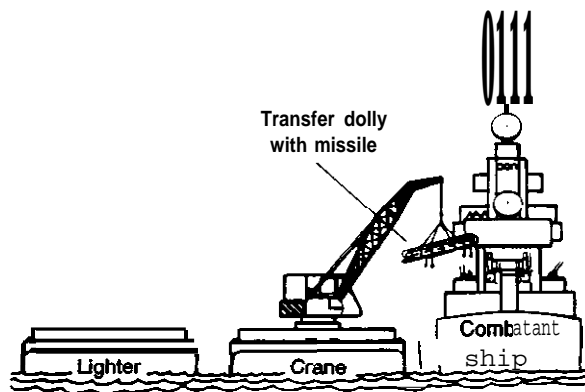

Lighter replenishment

SOURCE: P. Nagy, Center for International Studies, Massachusetts Institute of Technology.

### Testing

*Legal* testing of conventional SLCM airframe, guidance, and propulsion systems might substitute for much of the testing needed for a nuclear SLCM. Legal ALCM testing might also test many SLCM components, even if SLCM testing were illegal. In addition, OTA believes that covert testing might be possible because:

- SLCMs need not be tested to full range to demonstrate reliability (although they typically are).
- SLCMs can be tested to full range in racetrack patterns. This capability could be used in attempt to elude overhead systems by, for example, flying patterns in sites that are difficult to monitor using photo-reconnaissance satellites.
- SLCM tests could be performed at clandestine sites and at times when overhead sensors are not on station.
- Denial of telemetry from SLCMs is feasible; in addition, under existing arms control treaties, it would be legal.

### Deployment

- Transfer at sea, undeclared domestic ports, or foreign ports.<sup>60</sup> (See figure 5.)
- Hiding SLCMs below deck.<sup>61</sup>
- Covert launchers on undeclared surface ships.
- At-sea warhead conversion;<sup>62</sup> and at-sea warhead switching.<sup>63</sup>

#### *Ban Only Long-Range Nuclear SLCMs*

This option would ban the deployment or storage of any nuclear SLCM defined as “long-range.” Its foremost objective would be to eliminate Soviet nuclear land-attack SLCMs while preserving U.S. conventional land-attack SLCM programs. (The Soviets could also deploy conventional land-attack SLCMs should they develop this capability in the future.)

A hypothetical treaty that limited only long-range nuclear SLCMs would first define a range threshold for treaty accountability. ALCMs become accountable under START if their range is in excess of 600 km. Similarly, although they will not be limited by START, SLCMs with ranges in excess of 600 km will be subject to politically binding declarations. A treaty limiting long-range nuclear SLCMs with a 600-km threshold would currently affect the U.S. TLAM-N and the Soviet SS-N-21 (assuming the United States was satisfied with the accuracy of Soviet claims as to the range of their other cruise missiles). The United States can deploy the TLAM-N on both surface ships and on submarines. In contrast, the U.S. Department of Defense publication *Soviet Military Power* has only associated the SS-N-21 with submarine platforms.

The monitoring options and evasion paths for this arms option are similar to the total ban discussed above. Potential evasion paths unique to this option include extension of range and use of short-range antiship weapons for land-attack.

#### *Ban All Nuclear SLCMs on Surface Ships*

A proposal advanced by some U.S. defense analysts during the START negotiations would have restricted nuclear SLCMs to deployment on declared submarines, while allowing deployment of conventional SLCMs on permitted submarines and surface ships. Eliminating Soviet nuclear SLCMs from surface ships would have removed what was then part of the day-to-day nuclear threat to the U.S. Navy while leaving the United States with a great advantage in conventional capabilities, especially in its carrier task forces. Both the rationale for this option and the trend in U.S. naval nuclear deployments suggest that had this option been advanced by the United States, it might also have included a ban on

<sup>60</sup> The loading and unloading of SLCMs to ships from piers, floating docks, or tenders does not require any equipment other than a crane. Facilities for transfer can be located within national boundaries or at foreign ports. Loading operations of SLCMs on submarines would probably be indistinguishable from loading of torpedoes and could use standard torpedo loading equipment (SLCM in its loading canister might weigh as much as several thousand pounds more than a torpedo, but cranes and hoists rated to carry this weight would not be readily distinguishable from those that are not). See figure 5.

<sup>61</sup> Plausible only if SLCMs can be transferred between decks, for example, on an aircraft carrier.

<sup>62</sup> Assuming warheads are designed to allow the use of insertable nuclear components.

<sup>63</sup> This is not possible on the U.S. Tomahawk, but would be a concern if systems were designed a priori to allow rapid warhead exchange.

all nuclear weapons deployed on surface ships.<sup>64</sup> In the fall of 1991, the United States and the former Soviet Union took these steps unilaterally.

In this option, deployment of nuclear SLCMs on submarines is legal. As a result, both sides avoid the intrusiveness of submarine inspection while retaining the option of deploying a nuclear SLCM force. From a U.S. perspective, the challenge of treaty monitoring might be eased because the other side might have less incentive to violate a treaty that allows legal nuclear SLCM deployments. Furthermore, since nuclear SLCM deployments on submarines would be legal, the United States could anticipate that violations of the treaty would involve relatively large numbers of SLCMs, which are likely to be easier to detect. Note too that the United States would not monitor Russian nuclear SLCM production and storage facilities with onsite inspectors; such facilities would be legal in this option. Similarly, the United States would not have to tolerate reciprocal inspections at U.S. facilities.

Arguments in favor of a total ban on naval nuclear weapons deployed on surface ships include:

- . control of naval nuclear weapons is less reliable than that of central strategic forces,<sup>65</sup>
- there is the potential for nuclear escalation during a severe crisis or a conventional conflict because U.S. and Soviet surface fleets are likely to come into contact, thus adding pressure to “use or lose” nuclear weapons, and

. U.S. surface forces would be more effective in their conventional roles if they did not carry nuclear weapons.<sup>66</sup>

Arguments against a total ban on naval nuclear weapons deployed on surface ships include:

- the Soviet Union could legally deploy militarily significant numbers of nuclear SLCMs on submarines, and
- the Soviet Union could rapidly break out of treaty limits because:
  - a. their SLCMs are produced in conventional and nuclear variants, and
  - b. surface ship launchers could fire either type of SLCM.

In addition, there is a potential negotiating problem that stems from the asymmetry in U.S. and Soviet SLCM forces. The former Soviet Union did not deploy nuclear land-attack SLCMs on surface ships.

### *Launcher Limits*

Launcher limits would restrict the number of SLCM-capable launchers that could be legally deployed on either surface ships or submarines. An objective of a launcher limit would be to reduce the number of nuclear SLCMs that could be deployed at sea in a ready-launch configuration. An analogy to a launcher limit would be a limit on the number of intercontinental ballistic missile silos.

From a U.S. perspective, there would be at least two drawbacks to launcher limits. First, they might restrict the number of conventional SLCMs that could be deployed. Second, since SLCM launchers

<sup>64</sup> The U.S. Navy had eliminated the follow-on tactical nuclear weapons even before the President’s announcements of new policy on Sept. 27, 1991: the submarine-launched nuclear antisubmarine warfare rocket (SUBROC), the surface ship-launched nuclear antisubmarine warfare rocket (ASROC), and the Terrier surface-to-air missile. The President’s directive will remove the nuclear SLCM, TLAM-N; the B-57 nuclear bomb/depth bomb; and the B-61 nuclear bomb. The B-57 and B-61 are nuclear weapons that might be used by carrier aircraft; they were introduced into the Fleet in 1963 and 1968, respectively. At the time of the President’s speech, the only tactical nuclear weapon under development for the U.S. Navy was the B-90 nuclear depth/strike bomb. This weapon was intended to replace the B-57, but its deployment has now been delayed. The future of the B-90 was uncertain even before the President’s speech. See Norman Polmar, “Unilateral or Bilateral Nuclear Disarmament,” *The U.S. Naval Institute Proceedings*, vol. 117, No. 2, February 1991, pp. 105-106.

<sup>65</sup> Central strategic forces are usually defined as land and submarine-based intercontinental ballistic missiles and long-range bombers.

<sup>66</sup> These arguments include:

- . Nuclear weapons displace conventional weapons.
- Ships designated for nuclear weapons require additional maintenance and security personnel, whether or not weapons are on board.
- . Large amounts of magazine space are reserved for nuclear weapons, whether or not they are on board. (Note: this argument would not apply to nuclear Tomahawks because they are not stored in magazines.)

Those favoring elimination of nuclear weapons also argue that:

- Naval operating patterns are too uncertain to include nuclear weapons in many war plans; therefore, nuclear weapons are reserve weapons with little benefit to the U.S. deterrent against Soviet use of nuclear weapons.
- Short-range systems (e.g., a nuclear mine or surface-to-air missile) may not be usable without endangering the firing platform.

See, Adam B. Siegel, “‘Just Say No!’ The U.S. Navy and Arms Control: A Misguided Policy?” *Naval War College Review*, vol. 43, winter 1990, pp. 73-86.

are used to fire other weapons,<sup>67</sup> a launcher limit could interfere with a ship's capability to carry out vital defensive or offensive missions against enemy submarines, ships, and aircraft. A launcher limit set high enough to avoid these problems would also have little impact on the objective of limiting nuclear SLCM deployments.

A launcher limit might be monitored with overhead sensors in a manner similar to that adopted by SALT and START negotiators for counting the number of missile launch hatches on ballistic missile submarines. Hiding extra launchers below deck is a potential cheating scenario, but a cheater would face both operational and safety barriers in its execution. However, if necessary, this cheating scenario could be deterred by allowing shipboard inspections.

OTA envisions another cheating scenario using canisterized SLCMs. These could be hidden on surface ships and subsequently launched from make-shift launchers. This would be possible because canisterized weapons are self-contained and require little external support to be fired. As with the analogous cheating scenario of "soft-site" launch for canisterized ballistic missiles, one can either argue that this scenario is implausible because "this isn't how a navy operates" or one can argue that a determined cheater would be willing to break with normal operations.

*In Summary*, launcher limits could restrict the potential for large violations of a SLCM limit, but only if they were set so low that they would interfere with other defensive and offensive naval missions. Counting the number of SLCM-capable ships and launchers could be accomplished with NTM. Therefore, this option would not carry a large monitoring burden.

### *Attribution Rules for Deployed Nuclear SLCMs*

The START treaty applies an attribution rule for each heavy bomber declared to be a cruise missile carrier.<sup>68</sup> Nuclear SLCMs could be treated in a similar way, with separate attribution rules for each class of submarine or surface ship. The number and type of platforms that carry SLCMs could be communicated in a data exchange and verified with high confidence through NTM. The number of accountable nuclear SLCMs could then be included in future ceilings on all accountable nuclear warheads and platforms, or it could be included in separate subceilings.

This approach would bring nuclear SLCMs into an arms control framework. The monitoring requirements would depend on the type of attribution rule. One type of counting rule would assign a number of accountable SLCMs to a vessel, but allow deployments above (or below) this number. Another would treat the rule as a ceiling that could not be exceeded. In the former scheme, the number of attributable SLCMs would be simply the number of SLCM platforms, which can be monitored with NTM, multiplied by the attributed number of SLCMs.

There is no simple way to arrive at a "typical" nuclear SLCM loading for attribution purposes because launchers for SLCMs on submarines also fire torpedoes, and launchers for SLCMs on surface vessels also fire surface-to-air missiles. In addition, only a fraction (typically a very small fraction) of a ship's load of cruise missiles will be nuclear.

A counting rule that allowed deployments to vary from the attributed number of SLCMs per vessel would pose no monitoring burden. However, monitoring compliance with a rule that was a ceiling would be difficult using only overhead systems. Shipboard inspections could increase monitoring confidence, but only at the penalty of defeating an objective of this arms option, which is to make

<sup>67</sup> For example, the current mix of weapons that can be fired by U.S. Mk41 vertical launch system (61 launch cells), which is deployed on destroyers and cruisers, includes nuclear and conventional versions of the land-attack Tomahawk; conventionally armed antiship Tomahawks; and the Standard Missile, a conventionally armed solid-fuel rocket that is used for area defense against antiship missiles, aircraft, or ships. VLS could also be adapted to fire vertical launch versions of the ASROC antisubmarine missile and Harpoon antiship SLCM. Torpedo tubes also serve as multipurpose launchers. U.S. nuclear attack submarines are capable of firing torpedoes, conventionally armed Harpoon short-range SLCMs, and nuclear or conventional Tomahawk long-range SLCMs.

<sup>68</sup> The SALT treaties included limits on the number of land-based and submarine & based ballistic missile launchers. In addition, both SALT I and SALT II contained the following provisions: "For purposes of providing assurance of compliance . . . each Party shall use national technical means of verification. . . Each party undertakes not to interfere with the national technical means of verification of the other . . ."

<sup>69</sup> See footnote 39.

nuclear SLCMs accountable with a minimum monitoring burden. There would also be the possibility of large deployments beyond treaty limits if the number of attributed nuclear SLCMs for a vessel were substantially less than that vessel's maximum total nuclear and non-nuclear load.

In Summary, an attribution rule could be used to bring SLCMs into a formal arms control framework without imposing a large monitoring burden. However, compliance could not be monitored with certainty using only overhead systems.

### *Limits On The Design of Future SLCMs*

The United States currently does not plan to enter into a formal arms treaty to limit nuclear SLCMs. Nevertheless, the government may wish to take steps that would preserve this option for the future. The cost, level of intrusiveness, and effectiveness of a monitoring regime are key factors in the practicality of any arms accord. During the START negotiations, U.S. officials stated that they would oppose a SLCM treaty that allowed shipboard inspection, presumably because such an inspection is believed to be overly intrusive. An inspection whose objective was to find illegal nuclear warheads, or even smaller insertable nuclear components (INCs), would have to be even more intrusive.

An insertable nuclear component is a small nuclear device that would allow a conventional warhead to be rapidly converted to a nuclear warhead. Even a concerted search might not find an INC because its small size would allow it be hidden anywhere within a ship and its radiative emissions could be easily shielded. Warhead switching would be another way to convert a conventional SLCM to a nuclear SLCM. The warhead section of a SLCM, while much larger than an INC, is still substantially smaller than an assembled SLCM. The capability to use INCs, or to switch warheads, does not reside in U.S. SLCMs.

If the United States believes that convertible SLCMs could be an important problem in future arms negotiations, it could fund a modest research

program that would investigate the practicality of designing inherently nonconvertible SLCMs. The development of inherently nonconvertible cruise missiles might also be useful for distinguishing between nuclear ALCMs and long-range conventional ALCMs, should the latter be developed.<sup>70</sup>

Data exchanges and baseline inspections in a future treaty could verify that deployed SLCMs were legal at the time of treaty entry-into-force. Continuing compliance could be monitored by inspection of deployments, either by monitoring loading and unloading operations, or by onboard inspections. Problems in monitoring cruise missile production, test, and storage would prevent the United States from knowing if the Soviets were in compliance with an agreement that forbade development of convertible cruise missiles. The United States could, however, deter the deployment of convertible cruise missiles by randomly examining deployed weapons and subjecting them to intrusive inspection, for example, X-ray radiography. Monitoring compliance of day-to-day deployments could, over time, build confidence that dual-use SLCMs were not being produced.

### *Politically Binding Declarations*

A final option for nuclear SLCM arms control is to make long-range nuclear SLCMs the subject of binding declarations. This option was agreed to by Presidents Bush and Gorbachev at the Washington Summit in June 1990. Both sides agreed to make unilateral declarations of the upper limit on the number of long-range nuclear SLCMs they would deploy during a specified period. Although neither side was legally constrained by an arms control treaty from exceeding this limit, both sides agreed that the limits would be "politically binding."<sup>71</sup> Essentially, President Bush's address of September 27, 1991 called for the same arrangement with an upper limit of zero.

There is no explicit monitoring requirement for this option. However, the United States normally

---

<sup>70</sup> A provision of the START agreement requires that long-range conventional ALCMs be distinguishable from long-range nuclear ALCMs.

<sup>71</sup> The June 1990 limits were set at such a high level that they would not have constrained either side's SLCM programs or reduced the military utility of either side's SLCMs. Some U.S. analysts believed the declarations were merely a way of papering over important differences that would otherwise have prevented a START agreement. Others believed they had value because they would remove some of the secrecy that surrounds the Soviet SLCM program. Political declarations do not carry the legal constraints of a formal treaty; therefore, the United States would be free to alter its SLCM program in response to changing security needs, or in response to changes in Soviet SLCM forces.

devotes a portion of its NTM assets towards monitoring compliance with arms control agreements. As discussed above, limitations of NTM for monitoring nuclear SLCM production, storage, or deployment would not allow the United States to

monitor Soviet compliance with any degree of certainty. NTM would, however, let analysts count the number of SLCM-capable ships and launchers, perhaps placing an upper bound on the magnitude of potential violations.

A cruise missile, sometimes referred to as a pilotless jet aircraft, is an unmanned, aerodynamic vehicle powered by some form of jet engine. Guidance for the missile can be programmed autonomous (“launch and leave”); command (i.e., remotely piloted); or semi-autonomous. Arriving at an agreed definition of a sea-launched cruise missile would be the first step in any future arms control treaty and would have important implications for treaty monitoring. For example, a treaty could distinguish among cruise missiles by their maximum range, maximum speed, type of propulsion, or type of warhead.

Typically, the warhead and guidance system for a cruise missile are contained in the front part of the missile; the engine is in the rear and fuel occupies most of the midbody. Most currently deployed cruise missiles fall into one of two categories: long-range systems powered by highly efficient, miniature turbofan engines, and short-range systems powered by less efficient, and

presently less expensive, turbojet engines. Long-range cruise missiles fly at subsonic speeds in order to conserve fuel (a notably exception was the experimental Soviet SLCM, the SS-NX-24, which used an air-turbo rocket engine and flew at very high altitudes to reduce drag).

Cruise missiles initially evolved for two distinct missions—long-range attack of strategic targets on land and short-range attack of targets at sea or on the battlefield. These missions can now be accomplished by outwardly similar missiles. The latest development in cruise missile technology has been to design, in effect, a single weapon, which can be armed with a nuclear or a conventional warhead and adapted for launch from the ground, aircraft, surface ship, or submarine.

U.S. and Soviet antiship SLCMs were first developed and deployed in the 1950s, but the military utility of these systems was limited by their large size, short range, and

**Figure A-I—Tomahawk Missile System is an All-Up Round**

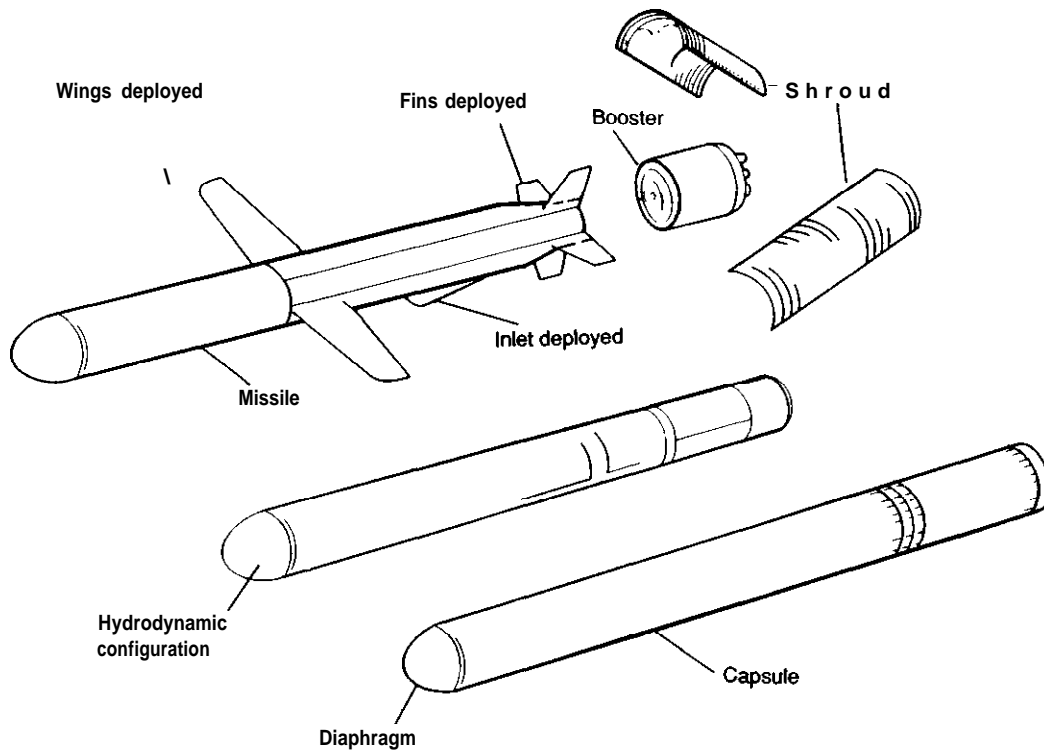

Each of the four Tomahawk SLCM variants—three for land-attack missions and one for antiship missions—is delivered to a ship or submarine as an all-up round (AUR), an encapsulated missile in a dry, gaseous nitrogen atmosphere. The Tomahawk AUR consists of the missile that flies the mission, the booster that starts its flight, and the container (canister for ships and capsule for submarines) that protects it during transportation, storage, and stowage. The container also acts as a Launch tube for the missile.

SOURCE: Department of Defense.

Figure A-2-SLCM Canisterization and Encapsulation Sequences

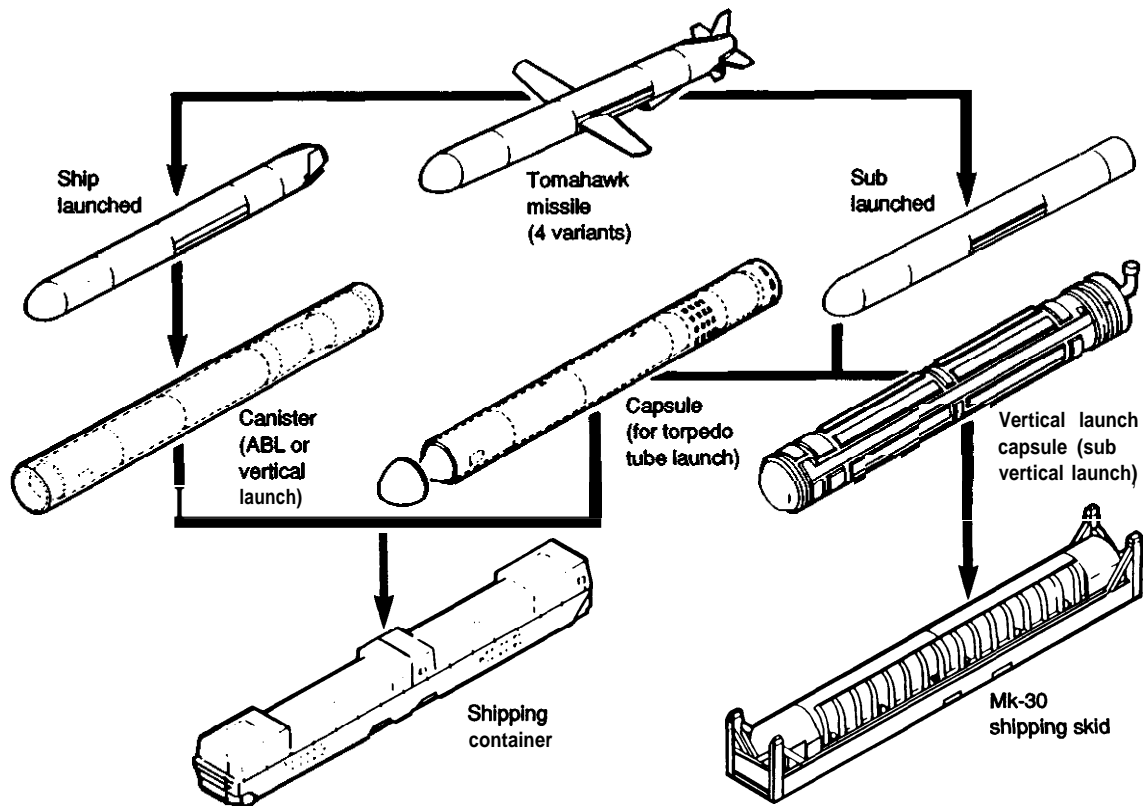

SOURCE: Department of Defense.

inaccuracy. In addition, early systems were not capable of underwater launch. Land-attack SLCMs from this period were similarly hampered by these limitations. The technologies that would make long-range, land-attack SLCMs practical did not reach maturity until the 1970s. The Soviet SS-N-21 "Sampson" and the U.S. "Tomahawk" nuclear land-attack missile (TLAM-N), first deployed in 1987 and 1983, respectively, exemplify these developments. Both fit into standard-size submarine torpedo tubes, have maximum ranges of approximately 2,500-3,000 km, and are capable of delivering a moderate yield nuclear weapon with an accuracy that maybe sufficient to destroy even hardened targets such as missile silos and launch control centers. SLCMs are relatively inexpensive weapons (if the cost of the weapon platform is neglected)—for example, the production cost of a nuclear Tomahawk, exclusive of the cost of the nuclear warhead, is about \$1 million.

The United States also deploys conventional versions of its nuclear land-attack SLCM. Conventional land-attack Tomahawks can deliver 1,000 pounds of chemical high-explosive at ranges up to approximately 1,300 km. They can be armed with either a single 1,000-pound warhead (TLAM-C) or with a submunitions dispensing

system (TLAM-D). The Tomahawk submunitions consist of 166 3.4-pound combined effects (armor piercing, fragmentation, and incendiary) "bomblets" that can be dispensed in 24 separate packages. Tomahawks are delivered to the Navy as "all-up" rounds. (See figure A-1 and A-2.) Planned "Block 3" upgrades to the unitary warhead of the Tomahawk include lighter weight and smaller volume warheads that will still be capable of producing the same explosive force as current models. Using the extra volume for fuel will extend the maximum range by approximately 50 percent. The Soviet Union has not developed a conventional variant of its long-range nuclear SLCM thus far. OTA believes that the "long pole" in the development of such a weapon would be the design of a guidance system accurate enough to allow target destruction using a chemical high-explosive warhead. (The United States accomplishes this with the DSMAC (Digital Scene Matching Area Correlator) guidance system. DSMAC is used on the TLAM-C and TLAM-D to update the inertial guidance system during missile final approach-to-target.)

U.S. antiship SLCMs are the short-range conventionally armed Harpoon and the long-range conventionally armed TASM (Tomahawk antiship missile).





*Photo credit: Jane's Strategic Weapon Systems*

A "Nanuchka" class corvette with two triple SS-N-9 "Siren" surface-to-surface missile canisters on deck.

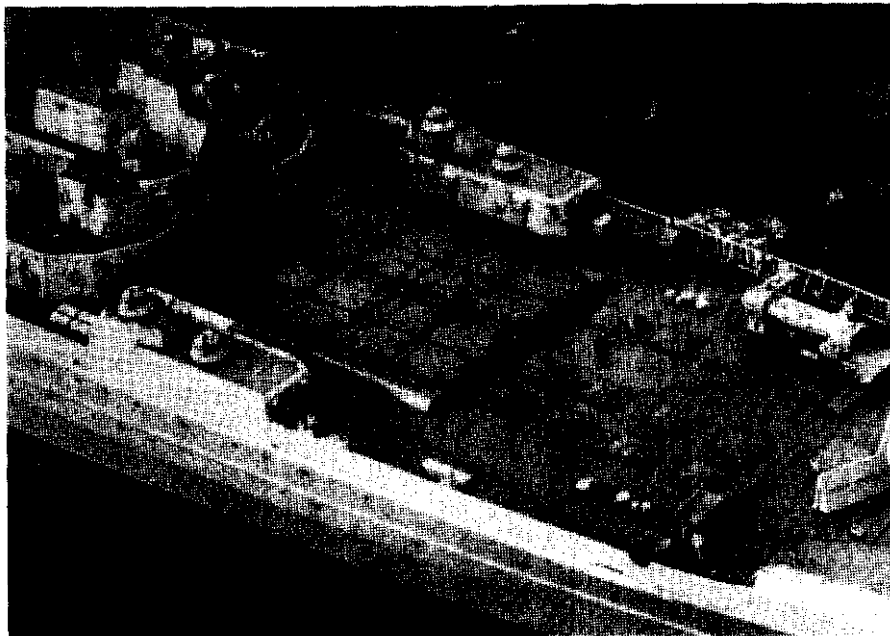

*Photo credit: Jane's Strategic Weapon Systems*

The Soviet battle cruiser Kirov, photographed in 1980, showing the 20 hatches on top of the vertical launch tubes for SS-N-19 "Shipwreck" missiles, with the smaller 12 hatches on the right of the picture for the SA-N-6 "Grumbie."

Antiship SLCMs differ from land-attack SLCMs in their guidance and, in some cases, in their propulsion. Because some targets will be at relatively close range, an antiship SLCM can be designed to trade fuel efficiency for increased speed or a less fuel-efficient (but less expensive) engine. The Soviet Union has deployed several

antiship SLCMs that have a supersonic capability; however, U.S. antiship SLCMs are designed to fly only at subsonic speeds.

The Soviet SS-N-21 and the U.S. Tomahawk are inherently stealthy. Their small size and small engines (600-pound thrust for Tomahawk) give them much

smaller radar, infrared, and acoustic signatures than manned bombers. In addition, these SLCMs can be programmed to fly sea-skimming flight profiles over water and low-altitude, terrain-following, flight paths over land.

On U.S. surface ships, Tomahawks are stored and launched from either an armored box launcher (ABL—four launch tubes protected by heavy armor and mounted on the ship's deck), or from an array of 32 or 64 vertical launchers (the vertical launch system, VLS) set into the deck. Vertical launchers can fire any missile adapted for vertical launch. For example, in addition to Tomahawk SLCMs, the United States currently deploys the Standard missile in VLS. The Standard missile is a conventionally armed solid-fuel rocket that could be used to defend against cruise missiles, aircraft, or ships. A foldable crane located in three VLS cells is used to reload Standard missiles from internal magazines, but it cannot be used to reload Tomahawks.

U.S. attack submarines (SSNs) can launch Tomahawk or Harpoon SLCMs through torpedo tubes. Some Los Angeles-class submarines have also been modified to allow vertical launch of Tomahawk from 12 dedicated launch tubes mounted outside the submarine's inner pressure hull (this particular vertical launch system is referred to as the "capsule launch system"). Soviet surface ships launch SLCMs with tube launchers similar

to U.S. box launchers or below-deck launch systems that are similar to U.S. VLS systems. Currently, Soviet surface ships are capable of launching only antiship cruise missiles (i.e., they have not been deployed with SS-N-21s). In contrast, the U.S. launches both antiship and land-attack SLCMs from its surface launchers. The U.S. VLS system also differs from the Soviet system in that its launch tubes are perpendicular to the deck, while the Soviet launch tubes are inclined.

The former Soviet Union deployed numerous submarines dedicated to SLCM launch (SSG/SSGNs), but these submarines were loaded only with antiship SLCMs. Long-range, land-attack SS-N-21s could be adapted for launch from any vessel with a standard-size torpedo tube. The 1989 edition of the Pentagon's *Soviet Military Power* stated that the Soviet Union could deploy the SS-N-21 on "specific classes of properly equipped current-generation or reconfigured submarines." Among the candidate platforms listed for the SS-N-21 were Akula- and Victor-class attack submarines and "Yankee Notch" submarines. The Yankee Notch is a former Yankee nuclear-powered ballistic missile submarine (SSBN) modified to fire SS-N-21s (extensive changes have been made to the center section, thus the term Yankee Notch or Yankee Notch-Waist). The nuclear-powered Yankee, which first became operational in 1988, is being replaced by more capable Delta and Typhoon-class SSBNs.